

1<sup>st</sup> Avenue South Bikeway Improvements  
Forward Pinellas Complete Streets Program  
2023 Funding Cycle - Construction Project Application

**1. Provide the name and contact information for the agency point of contact for this application.**

Name: Cheryl N. Stacks, P.E., AICP, Transportation Manager  
Postal Address: One 4th Street North, 8th Floor, St. Petersburg, FL 33701  
Email Address : [Cheryl.Stacks@stpete.org](mailto:Cheryl.Stacks@stpete.org)  
Phone: 727-892-5328

**1. Describe the project location. Include specific information on the project limits, jurisdiction of roadway and abutting properties, land use characteristics of abutting properties and any unique characteristics of the roadway (serves local/regional travel, serves a major activity center, etc.).**

The project is located on 1<sup>st</sup> Avenue South in downtown St. Petersburg where the Pinellas Trail is co-located as a two-way bikeway along the one-way street, and includes intersection improvements at three (3) intersections, specifically at 7<sup>th</sup> Street S, 5<sup>th</sup> Street S, and 2<sup>nd</sup> Street S. Improvements at the remaining intersections along the bikeway at Dr. M.L. King Street, 8<sup>th</sup> Street, 6<sup>th</sup> Street, 4<sup>th</sup> Street, and 3<sup>rd</sup> Street are expected to be included as a part of a separate, more significant transformation such that those locations are better addressed in the design and construction of those projects.

First Avenue South is a city-maintained roadway stretching 6.7 miles from bay to bay and serves as a part of a one-way pair that provides regional travel from downtown St. Petersburg to the western portion of Pinellas County. First Avenue South carries eastbound traffic through two general purpose lanes and a semi-dedicated transit lane to serve the new SunRunner Bus Rapid Transit (BRT) service. An eastbound bike lane exists from 34<sup>th</sup> Street to roughly 16<sup>th</sup> Street, where the bike lane transitions to a two-way cycle track to allow for cyclists' westbound access to the Pinellas Trail, adjacent to the 86-acre Historic Gas Plant District which is expected to undergo significant redevelopment in the next few years. The two-way bikeway was the first cycle track designed and constructed in the State of Florida when it opened in 2008. Consequently, the existing crossings for bicyclists and pedestrians are co-located leaving overly wide striped areas. Overhead, blanked-out signage has been added to advise turning motorists of their yielding responsibility, though the text is limited to "PEDS" with no mention of cyclists available. Reverse-oriented bicycle traffic signals have been installed at certain intersections by the Florida Department of Transportation (FDOT).

While the project involves only certain intersections along 1<sup>st</sup> Avenue South, it's worth noting the addition of BRT on the First Avenues, including 1<sup>st</sup> Avenue South increases its significance as a regional route for alternative transportation modes by providing a commuter service, travel to the beach, and convenient service for residents and tourists alike, with safe and comfortable first/last-mile connections becoming increasingly important. The project area is within St. Petersburg's urban core and contains many uses from high-density residential, general commercial, and mixed-use developments with planned increases in density anticipated in the future.

## 1<sup>st</sup> Avenue South Bikeway Improvements

The intersection of 1<sup>st</sup> Avenue South and 2<sup>nd</sup> Street South has signalized traffic control and was recently improved through the implementation of a pilot/demonstration project completed in partnership with Forward Pinellas to reduce motor vehicle turning speed, help shorten crossing distances, and separate bicyclist and scooters from pedestrians while crossing 2<sup>nd</sup> Street (a two-way street), and provide green pavement markings to increase visibility of the two-way bikeway for motorists, particularly those who are eastbound on 1<sup>st</sup> Avenue South. Elements of the current condition are considered an interim measure while other elements have been constructed with materials considered to represent a final configuration. The interim materials include modular curbing and flexible posts outlining a “wedge” to designate the appropriate turning radius for motorists. The more permanent infrastructure includes the separated crossings and relocated bicycle signal. Pictures of its before condition and existing condition are below. The intersection is located along the Downtown Looper route with trolley vehicles making the right turn. A City scooter parking corral is located at the southwest corner of the intersection on 1<sup>st</sup> Avenue South. Directly adjacent to the intersection are several restaurants, apartments, a parking garage, and The James Museum.



*Before interim intersection improvements*

## 1<sup>st</sup> Avenue South Bikeway Improvements



*After intersection improvements including interim “wedge” island*

The intersection of 1<sup>st</sup> Avenue South and 5<sup>th</sup> Street South has signalized traffic control and a far-side SunRunner BRT station is located on the east side of the intersection on 1<sup>st</sup> Avenue South. It’s the last eastbound station before the service makes a turn to go south towards the Innovation District and is consequently the first station most people arriving from the west will experience in the City’s downtown core. On the west side of the intersection is one of the City’s Scooter Share parking corrals within the footprint of the bikeway. Directly adjacent to the intersection is the Florida Holocaust Museum, office buildings, and a bank. The Residences at 400 Central is currently under construction adjacent to the intersection and will be the City’s largest tower when completed. The tower is planned to be a 1.3 million square-foot development with 301 luxury units, ground-floor retail and restaurants, and Class A office space. Finally, there is also a senior housing development nearby that houses many residents with mobility issues.

Lastly, the intersection of 1<sup>st</sup> Avenue South and 7<sup>th</sup> Street South is currently unsignalized with enhanced crosswalks across 1<sup>st</sup> Avenue South, on both sides of the intersection that are enhanced with Rectangular Rapid Flashing Beacons (RRFB) located on each side of 7<sup>th</sup> Street. Similar to the crossings at the signalized intersections, the crosswalk across 7<sup>th</sup> Street is currently very wide and shared between the trail and sidewalk with no markings to differentiate them. Directly adjacent to the intersection is a multi-story apartment building, restaurant, and office building. A grocery store and multiple restaurants are within a block of this intersection.

- 2. Describe in detail the proposed improvements that will be provided by the project, including the following, as applicable:**
  - a. Pedestrian accommodations being added/enhanced;*

## 1<sup>st</sup> Avenue South Bikeway Improvements

The pedestrian accommodations will be enhanced through the permanent installation of the existing improvements at the 1<sup>st</sup> Avenue S and 2<sup>nd</sup> Street S intersection which separate the crossings and provides an exclusive crosswalk for pedestrians. The wedge island shortens the crossing distance for pedestrians and slows the turning vehicles using a tighter radius, improving safety and reducing potential for conflict. The improvements are to be constructed in concrete giving them a sense of permanence that users can rely upon when making transportation and/or land use decisions. The intersections of 1<sup>st</sup> Avenue South at 5<sup>th</sup> Street South and 7<sup>th</sup> Street South currently do not have the interim installation of the bulb-out marked with white flex posts or the green bikeway markings. There are significant visibility concerns with the existing, wide crossings. Implementing the enhanced treatments of the wedge island and separated crossings will improve the safety for pedestrians. Bicyclists and motorized scooters travel at much faster speeds than pedestrians, thus separating the users while crossing can help reduce the potential for conflicts. Further, the wedge island will shorten the crossing distance for pedestrians and slow vehicle traffic, resulting in a safer environment for pedestrians at these intersections, 5<sup>th</sup> Street and 7<sup>th</sup> Street, as well.

### *b. Bicycle facilities being added/enhanced;*

The crosswalks along the 1<sup>st</sup> Avenue S bikeway at 5<sup>th</sup> Street South and 7<sup>th</sup> Street South are wide and provide shared markings for both the sidewalk and the bikeway, creating potential for conflict between bicyclists, pedestrians, and e-scooter riders. The crossings will be separated with green markings added to help reduce conflicts between them. The green markings will also increase the visibility of the trail crossing and reduce conflicts between vehicles and bikeway users. The installation of the green markings at the 2<sup>nd</sup> Street South intersection have received positive feedback from users that their perception of safety has increased due to the enhancements.

### *c. Sidewalks and/or bicycle facilities along an adjacent roadway segment that truncate at the project limits;*

The sidewalks and separated bikeway are continuous throughout the project. Enhancements focus on creating safer crossings and reducing conflict points for all users.

### *d. Existing and proposed transit service along the corridor, including frequency of service;*

Several Pinellas Suncoast Transit Authority (PSTA) transit routes run along this section of 1<sup>st</sup> Avenue South, including the new SunRunner BRT service which operates through both the 7<sup>th</sup> Street and 5<sup>th</sup> Street intersections, though not the intersection at 2<sup>nd</sup> Street. The SunRunner service runs from 6 a.m. to midnight, with 15-minute headways until 8 p.m. and 30-minute headways between 8 p.m. and midnight. The Downtown Looper service operates for free and acts as a downtown circulator with 15–20-minute headways from 7 a.m. to 10 p.m. on weekdays and 8 a.m. to 10 p.m. on weekends. Route 7 generally has 60-minute headways from 9 a.m. to 9 p.m., while Routes 9 and 23 generally have 30-minute headways from 6 a.m. to 9 and 10 p.m. Route 18 has served the corridor within the project limits in the past and is amongst those routes that have been truncated due to overlaps in SunRunner service.

## 1<sup>st</sup> Avenue South Bikeway Improvements

The ridership for all the routes that ran through the corridor as of 2021 are in the chart below.

| Route  | FY 2021 Ridership |
|--------|-------------------|
| 7      | 164,892           |
| 9      | 366,036           |
| 15     | 165,467           |
| 18*    | 792,164           |
| 23     | 180,905           |
| 100X   | 62,687            |
| Looper | 44,158            |

*e. How the project will provide accommodations for transit riders along the corridor;*

SunRunner service is likely to increase transit use of new, choice riders, and tourists from the beach or from the western portion of the county to Downtown. Thus, pedestrian and bicyclist traffic will likely increase due to the nearby SunRunner stations. The last eastbound stop in downtown is located at one of the projects intersections (1<sup>st</sup> Avenue South and 5<sup>th</sup> Street South) and will likely see many riders exiting to access downtown. The separation of the crossings for pedestrians and bicyclists or scooter users will help provide clarity for transit users who may be less familiar with downtown and create a safer environment, generally, for all transit users.

*f. Documented safety concerns along the corridor (e.g. high crash rate, high number of crashes involving vulnerable users, etc.). How will the project improve safety for all users? Forward Pinellas is available to provide assistance in compiling this data to support your application;*

The 1<sup>st</sup> Avenues have consistently been an issue in terms of speed and high crash rates, even in the downtown core where speeds are expected to be lower. The crash data for 2017-2021 is represented on the map below and illustrates traffic crash hotspots for a ¼-mile radius from the project area. There have been numerous pedestrian and bicycle crashes at the three intersections in the project scope. At the 2<sup>nd</sup> Street and 1<sup>st</sup> Avenue South intersection, crashes have decreased from an average of 6 crashes annually to 4 crashes after interim enhancements were added. The intersections of 1<sup>st</sup> Avenue South at 5<sup>th</sup> Street and 7<sup>th</sup> Street have relatively low numbers of reported crashes but could reasonably expect to realize the safety benefits that have been seen since the interim improvements were added.

| Characteristic              | Speed (mph)<br>– Before | Speed (mph)–<br>After |
|-----------------------------|-------------------------|-----------------------|
| Sample Size                 | 95                      | 40                    |
| Minimum Speed               | 5                       | 3                     |
| Maximum Speed               | 32                      | 24                    |
| Mean Speed                  | 17                      | 16                    |
| 50 <sup>th</sup> Percentile | 16                      | 16                    |
| 85 <sup>th</sup> Percentile | 23                      | 19                    |

## 1<sup>st</sup> Avenue South Bikeway Improvements

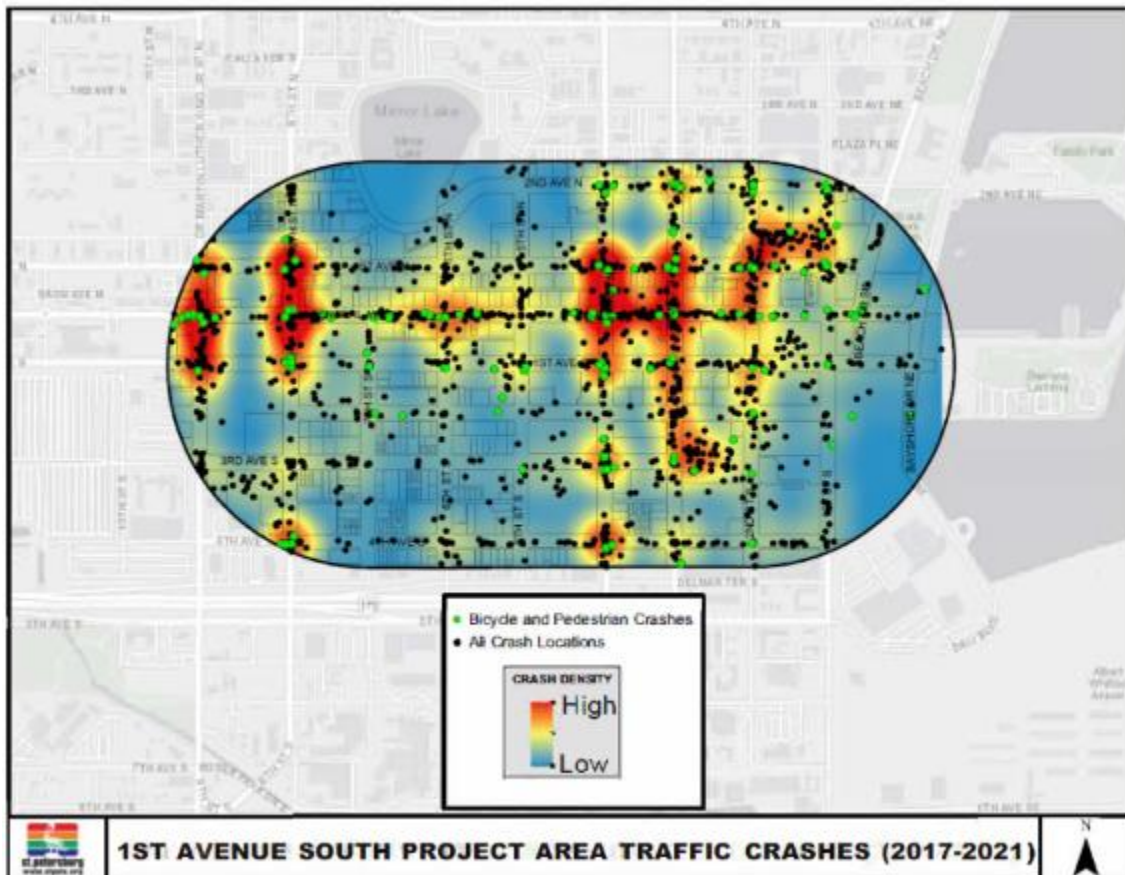

In addition to the crash reductions, the demonstration project of interim improvements at 1<sup>st</sup> Avenue South and 2<sup>nd</sup> Street South has resulted in speed reductions with the 85<sup>th</sup>-percentile speed reduced from 23 miles per hour to 19, a speed at which survival rates are extremely high if a vulnerable road user is hit by a motorist. Near misses were also observed at much lower rates during the speed study due to the enhancements.

*g. Access/connections to Activity Center(s) or Multimodal Corridor(s), as designated on the Transit Oriented Land Use Vision Map (see link: <https://bit.ly/3uNH8bm>);*

1<sup>st</sup> Avenue South is identified on the Transit Oriented Land Use Vision Map as a primary corridor and is a part of a “special center,” Downtown St. Petersburg, which is home to many activity centers. It is also identified as a Primary Multimodal Corridor.

*h. Is the project segment within an adopted CRA?;*

This project is a part of the Intown Redevelopment Area, the second largest CRA within St. Petersburg. The intersections of 1<sup>st</sup> Avenue South and 2<sup>nd</sup> and 7<sup>th</sup> Streets are located entirely within the CRA while the intersection at 5<sup>th</sup> Street is on the boundary of the CRA.

## 1<sup>st</sup> Avenue South Bikeway Improvements



- i. *Does the project corridor have street lighting? Will the project add/enhance street lighting along the corridor?;*

There is ample lighting along the corridor and enhanced lighting is not within the scope of the current project.

- j. *Access management strategies.*

Where commercial driveways are located near the intersections and intersect with the bikeway, green pavement markings will be continued to increase the visibility of bicyclists along the bikeway. The City standard for this type of crossing was developed following the initial construction of the bikeway and consequently not all driveways have included this element.

**3. Provide detailed project cost information and documentation of the local match being provided by the applicant.**

The estimated total project cost is \$645,057 that includes an estimated \$115,189 for design, \$460,755 for construction, and \$69,113 for CEI services. A detailed project cost estimate is included within the attached Transportation Alternatives application. The City's match will include the design phase and CEI services, again estimated to be approximately \$184,302

## 1<sup>st</sup> Avenue South Bikeway Improvements

which represents nearly 30-percent of the total project costs. It will be funded through the City's Complete Streets program funding, which has annual funding apportioned to match the \$3M included in the fourth round of the City's Penny for Pinellas funding which continues through 2030. An excerpt of the FY23 Budget in Brief which illustrates this year's allocation of \$450,000.

It's worth highlighting the successful partnership between Forward Pinellas and the City to complete the interim improvements made through paint and temporary infrastructure at 1<sup>st</sup> Avenue South and 2<sup>nd</sup> Street through the Safe Streets Pinellas program. Concept planning and project evaluation services were provided by Forward Pinellas through an initial investment, while the detailed design and construction were completed by the City through an investment of approximately \$80,000.

**4. *Describe any barriers to connecting low income or elderly communities with activity centers that exist along the project limits, and how the proposed project will address them.***

The project is located entirely within an activity center, though access for people with low incomes and/or who are elderly is expected to be improved based on the nature of the project that will improve the safety and comfort of the intersection crossings of the bikeway and adjacent sidewalks. Additionally, the Lutheran Apartments tower, located between 6<sup>th</sup> Street South and 5<sup>th</sup> Street South on 1<sup>st</sup> Avenue South, is an affordable, senior living complex that houses many residents with mobility issues. The prevalence of transit along the corridor and the Publix grocery store that many walk to through the 7<sup>th</sup> Street intersection demands safer intersections that minimizes or avoids conflicts for all users, especially those with mobility issues who may take longer to cross. The Publix grocery store is located on the north side of 1<sup>st</sup> Avenue encouraging shoppers who walk to the store from the south to cross three lanes of traffic at an unsignalized intersection. The anticipated turn wedge is expected to help slow motorists' speeds on the approach to 7<sup>th</sup> Street, thereby improving safety for all roadway users regardless of the crossing they need to make.

**5. *Describe the local planning requirements that make the area surrounding the project corridor supportive of multimodal transportation improvements. For example, does the local land use plan encourage mixed use development? Does the local land development code require buildings to be located adjacent to the ROW line or enable reduced surface parking? Does the local plan facilitate connectivity of local road, bicycle and/or pedestrian networks? Please refer to the Planning and Urban Design Principles in the Forward Pinellas Countywide Plan for more examples of desired local planning requirements (see link below). (<https://bit.ly/2YwRLnt>)***

The City's Comprehensive Plan includes language that's supportive of multimodal transportation improvements in several sections within the Transportation and Land Use Elements and is supported by the Complete Streets Implementation Plan which was adopted in 2019 and is expected to be more fully incorporated within the Comprehensive Plan in its next significant update. Similarly, recommendations from the SunRunner Rising study to improve transit-oriented development adjacent to the 1<sup>st</sup> Avenues and SunRunner route will be included as well.



## 1<sup>st</sup> Avenue South Bikeway Improvements

With regard to zoning, the areas directly adjacent to 1<sup>st</sup> Avenue S at 7<sup>th</sup> Street and 5<sup>th</sup> Street are zoned as Downtown Center – 1 (DC-1) and Downtown Center – Core (DC-C) at 2<sup>nd</sup> Street. The Downtown Center – Core District allows for the most density, intensity, and building height to provide a vibrant and diverse downtown. Mixed-use is required and uses that place an emphasis on vehicular access are discouraged. The Downtown Center – 1 District also encourages mixed-use development with a preference towards office and employment uses. Any development must promote pedestrian-grade orientation rather than be built to prefer vehicle access. Further, 1<sup>st</sup> Avenue South is a “B” street in the project area, meaning at least 20% of the of the non-residential uses must be pedestrian-oriented uses including retail, museums, and other general commercial or service industry uses.

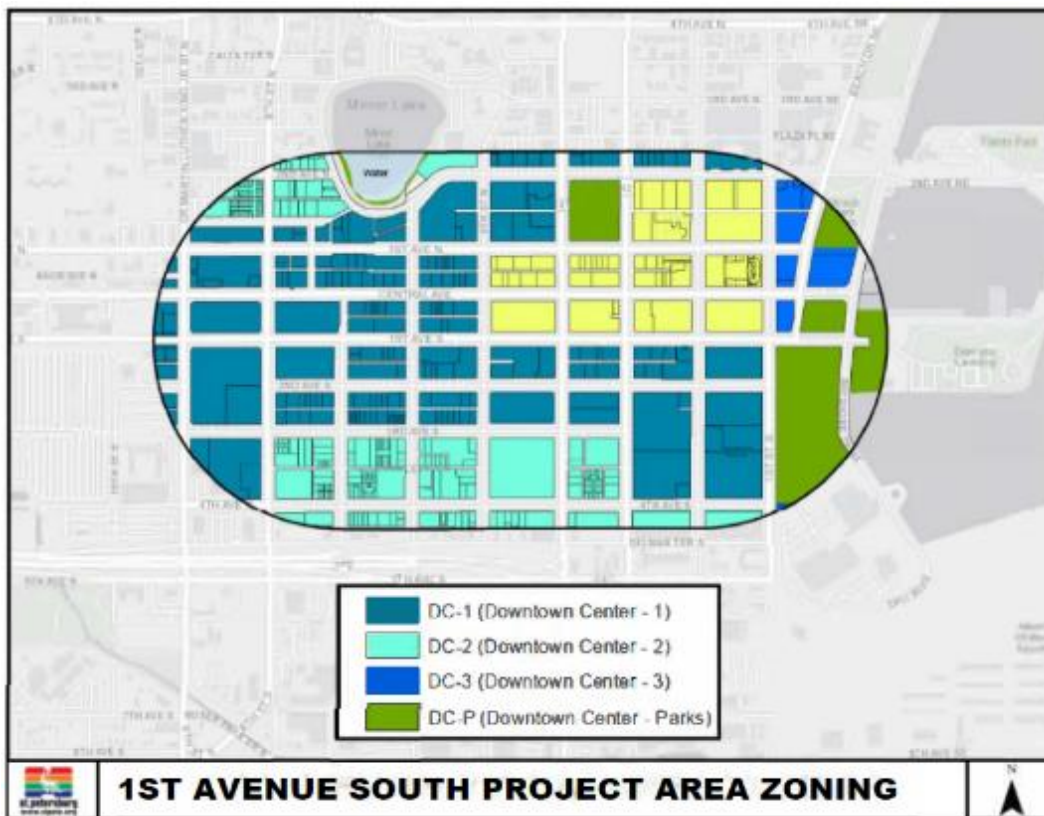

## 1<sup>st</sup> Avenue South Bikeway Improvements

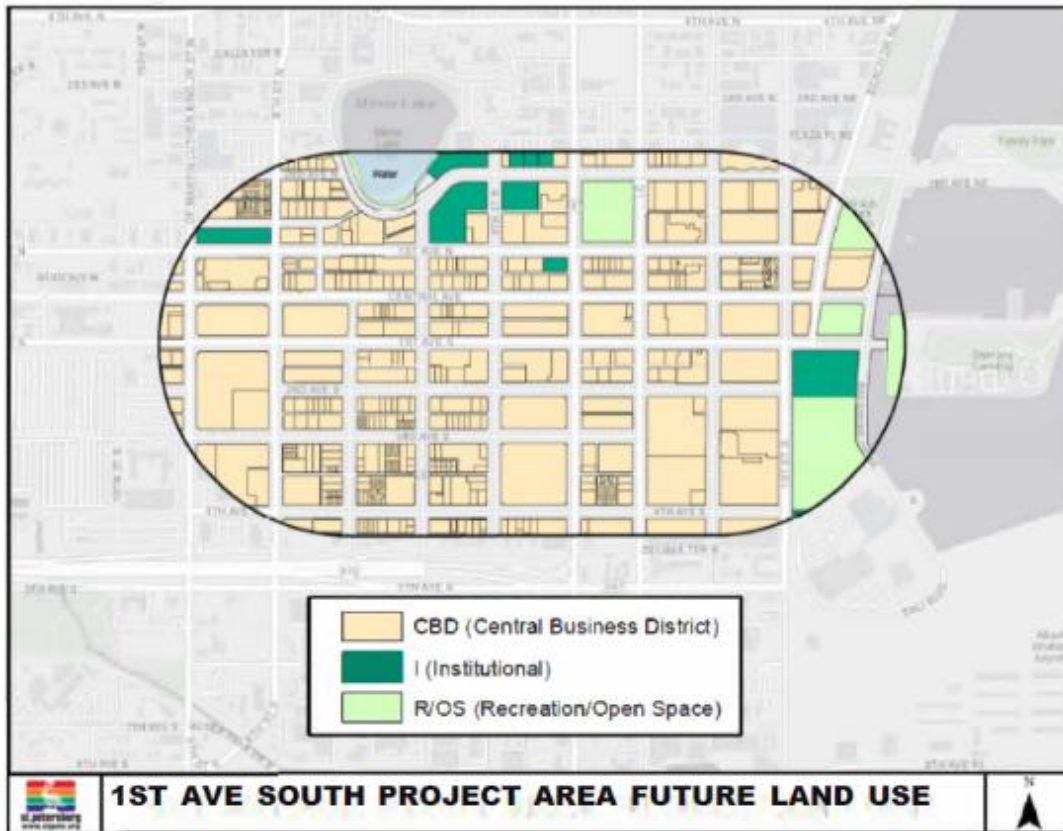

Vehicular parking requirements in the Downtown Center zoning requires parking to be on-street or not visible from the street in the form of structured parking to ensure pedestrian-oriented development. The minimum parking requirement for multifamily units in downtown is 1 parking space per unit above 750 square feet. Recent amendments to the City's code allows development of accessory dwelling units or residences less than 750 square feet without a requirement to meet a vehicular parking minimum. Bicycle parking is required city-wide for new development regardless of use. Both long-term and short-term parking are required for visitors, customers, and employees. Any long-term bicycle parking must be secure and partially covered to encourage bicycle usage as a form of commuting. For multifamily residential, a minimum of one long-term parking space required per-unit which applies in the project area and citywide.

Lastly, the City does have a Complete Streets Policy and Implementation Plan that outlines a network of safe and comfortable, connected infrastructure for for pedestrians and bicyclists throughout the city. The project area is supported by this language and works to enhance the safety and comfort of the existing bikeway.

**6. *Provide a project schedule to highlight the anticipated timeline to complete the project.***

Design is anticipated to take between 9-12 months and will be coordinated to precede the availability of construction funds. Construction and project completion would likely come 12 – 18 months after funding award and LAP approval. A summary timeline is provided below.

## 1<sup>st</sup> Avenue South Bikeway Improvements



**7. What percentage of parcels along the corridor are vacant?**

16.48% of the parcels within ¼-mile of 1<sup>st</sup> Ave S between 7<sup>th</sup> St and 2<sup>nd</sup> St are currently vacant.

**8. Describe how the parcels along the corridor are underdeveloped or underutilized and would benefit from complete streets treatments.**

In recent years, vacant parcels along this corridor are typically vacant for short periods of time and are quickly redeveloped or currently under construction. Due to the flexible zoning, many parcels are redeveloped to higher density and intensity, requiring better infrastructure for users that are within downtown. Utilization is expected to increase when the walkability, bikeability, and overall perception of comfort increases, especially as more developments are completed while meeting the strong long-term bicycle requirements (1 per unit).

**9. Provide the percentages of each existing land use category that is within ¼ mile of the centerline of the roadway included in this application.**

| PROPERTY USE  | ACRES | PERCENT |
|---|-------|---------|
| GENERAL OFFICE BLDG - MULTI-STORY/CAMPUS  | 17.78 | 10.70%  |
| CITY GOV'T - NON-RESIDENTIAL (COMMERCIAL) ONLY  | 17.75 | 10.68%  |
| APARTMENTS (50 UNITS OR MORE)   | 16.71 | 10.06%  |
| VACANT COMMERCIAL LAND W/XFSB   | 13.00 | 7.82%   |
| VACANT COMMERCIAL LAND  | 11.78 | 7.09%   |
| STRIP STORE - (2 OR MORE STORES)  | 8.76  | 5.27%   |
| CONDOMINIUM   | 6.93  | 4.17%   |
| GENERAL OFFICE  | 6.25  | 3.76%   |
| HOTELS AND MOTELS (50 UNITS OR MORE)  | 5.33  | 3.21%   |
| NEIGHBORHOOD SHOPPING CENTER  | 4.42  | 2.66%   |
| MARINA - BOAT STORAGE (HIGH & DRY AND/OR WET SLIP)  | 4.37  | 2.63%   |
| SEWAGE DISPOSAL, SOLID WASTE, DRAINAGE RESERVOIRS, BORROW PIT, MARSH, MANGROVE, SAND DUNE, WASTE LAND | 4.33  | 2.61%   |
| COUNTY GOV'T - NON-RESIDENTIAL (COMMERCIAL) ONLY  | 3.43  | 2.06%   |
| PLANNED UNIT DEVELOPMENT  | 3.26  | 1.96%   |
| APARTMENTS (10 - 49 UNITS)  | 3.06  | 1.84%   |
| CLUB, LODGE, UNION HALL, CIVIC CLUB, HEALTH SPA   | 2.59  | 1.56%   |
| CHURCH, CHURCH SCHOOL, CHURCH OWNED BUILDING (PARSONAGE CODE 0110), SALVATION ARMY, MISSIONS          | 2.57  | 1.55%   |

## 1<sup>st</sup> Avenue South Bikeway Improvements

|  |               |               |
|--|---------------|---------------|
| CONDO CONVERSION - APARTMENTS TO PLATTED CONDO (PREDOMINATELY OWNER-OCCUPIED)            | 2.47          | 1.49%         |
| RESTAURANT, CAFETERIA  | 2.47          | 1.49%         |
| SUPERMARKET & SUPERSTORE   | 2.21          | 1.33%         |
| CONDO - COMMERCIAL - STORE (UNIT)  | 2.09          | 1.26%         |
| CONDO COMMON AREA ASSN OWN - W/IMPROVEMENT   | 1.80          | 1.09%         |
| PARKING GARAGE - CONDO   | 1.82          | 1.09%         |
| VACANT CONDO (DEVELOPMENT LAND)  | 1.65          | 1.00%         |
| APARTMENTS (5-9 UNITS)   | 1.63          | 0.98%         |
| SINGLE BUILDING STORE  | 1.47          | 0.89%         |
| PAID PARKING   | 1.45          | 0.87%         |
| CONDO OFFICE (UNIT)  | 1.33          | 0.80%         |
| DUPLEX-TRIPLEX-FOURPLEX  | 1.32          | 0.79%         |
| STATE GOV'T - NON-RESIDENTIAL (COMMERCIAL) ONLY  | 1.17          | 0.70%         |
| TELEPHONE COMPANY PROPERTY - OFFICE & BUILDING   | 1.16          | 0.70%         |
| FINANCIAL INSTITUTION  | 1.10          | 0.66%         |
| ALF (10 OR MORE UNITS)   | 1.08          | 0.65%         |
| LITERARY, SCIENTIFIC & CULTURAL FACILITIES   | 0.99          | 0.59%         |
| CONDO COMMON AREA ASSN OWN - OPEN/GREEN SPACE  | 0.92          | 0.55%         |
| VACANT RESIDENTIAL - LOT & ACREAGE LESS THAN 5 ACRES                                     | 0.91          | 0.55%         |
| PUBLIC COLLEGES, SPC, USF  | 0.72          | 0.43%         |
| BAR, WITH OR WITHOUT PACKAGE STORE   | 0.57          | 0.34%         |
| SINGLE FAMILY HOME   | 0.57          | 0.34%         |
| CONDO COMMON AREA ASSN OWN - RIGHT-OF-WAY, STREET, ROAD, IRRIGATION CHANNEL, DITCH, ETC. | 0.52          | 0.32%         |
| MEDICAL OFFICE BUILDING - SINGLE & MULTI-STORY   | 0.48          | 0.29%         |
| FEDERAL GOV'T - NON-RESIDENTIAL (COMMERCIAL) ONLY  | 0.39          | 0.24%         |
| ENCLOSED THEATER   | 0.38          | 0.23%         |
| HOTELS AND MOTELS (49 UNITS OR LESS)   | 0.35          | 0.21%         |
| MINI-STORAGE WAREHOUSE   | 0.34          | 0.20%         |
| INDUSTRIAL NOT CLASSIFIED ELSEWHERE  | 0.19          | 0.11%         |
| SUBDIVISION COMMON AREA - OPEN/GREEN SPACE, ASSN OWNED                                   | 0.17          | 0.10%         |
| RAILROAD PROPERTY - ASSESSED BY COUNTY APPRAISER   | 0.08          | 0.05%         |
| VACANT RESIDENTIAL LAND W/XFSB   | 0.03          | 0.02%         |
| RIGHT-OF-WAY STREET AND ROAD, IRRIGATION CANAL, CHANNEL, DITCH, ETC.                     | 0.0043        | 0.003%        |
| <b>TOTAL</b>   | <b>166.14</b> | <b>100.00</b> |

**10. Is the project located in an area designated by Forward Pinellas as an Environmental Justice area? For minority, low income or both?**

The entire project is located in an area identified as a Low-Income Environmental Justice tract as noted in the below extracted image from page 4-52 of the 2045 Pinellas Long Range Transportation Plan.

# 1<sup>st</sup> Avenue South Bikeway Improvements

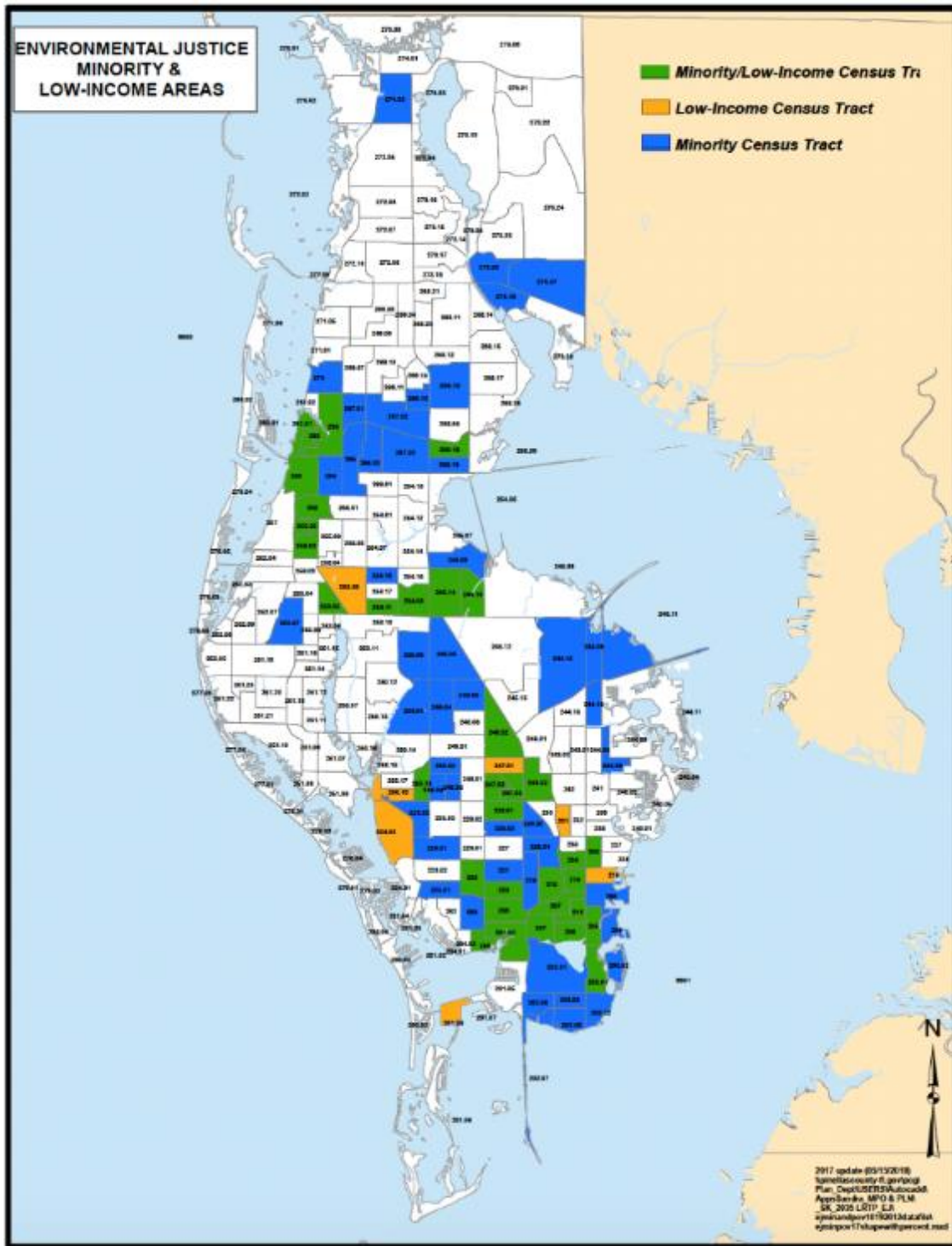

<https://bit.ly/3iyHfmp>

**11. Describe how the transportation disadvantaged (persons with disabilities, children, the elderly and low income) populations will be served by the improvements proposed.**

Shortening the crossing distance and slowing turns protects users with mobility issues that may cross slower or be noticed less quickly. Walking for transportation is prevalent in

## 1<sup>st</sup> Avenue South Bikeway Improvements

Downtown St. Petersburg, whether that be by choice or necessity, and improving safety helps everyone, especially the transportation disadvantaged, by better connecting users to food access, work, educational opportunities, recreation, and medical trips. The project will help enhance access to the SunRunner service with considerable benefit for transportation disadvantaged residents in the project area and accessing the Downtown St. Petersburg.

**12. Describe how the project would increase access to healthy food for minority, low-income or both populations in the abutting and adjacent communities.**

There is a Publix grocery store just past the 7<sup>th</sup> Street intersection and across 1<sup>st</sup> Avenue South that many downtown residents can walk, cycle, or ride scooters to. Further, there is another Publix located approximately 3 blocks away of the intersection of 1<sup>st</sup> Avenue South and 2<sup>nd</sup> Street, immediately adjacent to a SunRunner station. Improving safety through this project can help improve access for those who may feel unsafe or unable to reach these stores due to safety concerns with the speeds of traffic on adjacent streets.

**13. If awarded a construction grant, coordination with Forward Pinellas to conduct before/after analysis on the corridor, as well as drone photography, will be required. No direct financial support is required from the local government partner for this analysis.**

The City of St. Petersburg acknowledges that a before/after study will be conducted and supports this effort.

**14. If awarded a construction grant, Forward Pinellas will work with the applicant to retrieve current signal timing plans for intersections within the project limits to analyze the impact of existing signal operation on the goals and objectives of the project.**

The City of St. Petersburg acknowledges this and is willing to offer its support to adjust signal timing as needed to meet the goals of this construction project.

**15. Provide a completed FDOT Consolidated Project Application for "Transportation Block Grant and Transportation Alternative Set-Aside Funding".**

<https://www.fdot.gov/planning/systems/tap/default.shtm>

A completed Transportation Alternatives application is attached.

## 1<sup>st</sup> Avenue South Bikeway Improvements

### Attachments

1. City Council resolutions documenting project and grant application support
  - a. 2019-226 approving the Complete Streets Implementation Plan
  - b. 2015-540 supporting the Complete Streets Policy
  - c. 2014-162 approving Administration submittal of grant application(s)
2. FY23 Approved Capital Improvements Program excerpt illustrating annual capital funding to demonstrate local funding support
3. Completed Transportation Alternatives application and associated attachments

NO. 2019-226

A RESOLUTION APPROVING THE ST. PETERSBURG COMPLETE STREETS IMPLEMENTATION PLAN (“PLAN”); AUTHORIZING THE CITY ADMINISTRATION TO MAKE NON-SUBSTANTIVE CHANGES AS NECESSARY TO THE DRAFT PLAN PRIOR TO PUBLICATION OF THE FINAL PLAN; AND PROVIDING AN EFFECTIVE DATE.

WHEREAS, the City of St. Petersburg (“City”) Comprehensive Plan’s Vision Element directly supports the principle that mobility afforded to the individual is fundamental to the success of the City’s land use and transportation system; and

WHEREAS, through implementation of the City’s Complete Streets Program, streets are designed and operated to promote safety and accessibility for all users of the transportation network, including pedestrians, bicyclists, transit riders, motorists, commercial and emergency vehicles, and people of all ages and physical and economic abilities; and

WHEREAS, the City has stated its desire for inclusion of a Complete Streets philosophy within the Transportation Mission Statement in the Vision Element, which states: “St. Petersburg will have a livable balance of connected transportation options for all of its citizens. Pedestrian and bicycle facilities shall be designed, encouraged and celebrated as indicators of a healthy city. Public transit shall be sensitive to the context of neighborhoods and integrated into future economic and development plans”; and

WHEREAS, the City recognizes the potential benefits to its sustainability efforts, the local economy, and other positive transformations that may occur with investments made in implementing Complete Streets; and

WHEREAS, the City has a significant interest in maintaining a sustainable transportation system, and increasing the opportunity for bicycle and pedestrian travel as an alternative to the automobile which reduces the City’s reliance on fossil fuels which places the City of St. Petersburg in a position to more effectively reduce greenhouse emissions and improve air quality; and

WHEREAS, St. Petersburg desires to be a city of opportunity whereby the health and wellness of its citizens is considered vital to the overall shared success of the City and a



transportation network that considers the needs of all users will be a key component toward providing access to healthy lifestyles; and

WHEREAS, the City desires to complement the efforts being adopted by communities across the nation at all levels of government, including the Federal Safe Streets Act of 2014; the Florida Department of Transportation, which has adopted a Complete Streets Policy; and the Pinellas County Transportation Plan, which includes an endorsement of Complete Streets elements; and

WHEREAS, on November 2, 2015, the Complete Streets City Administrative Policy #020400 became effective, which included the requirement to create and adopt the Complete Streets Implementation Plan (“Plan”); and

WHEREAS, on November 12, 2015, City Council passed Resolution 2015-540, wherein the Council affirmed its support of the Complete Streets Program and Administrative Policy #020400, thus launching the development of the Plan; and

WHEREAS, since July 2016, the City’s Complete Streets Committee has convened monthly to guide Plan development; and

WHEREAS, on November 10, 2016, City Council approved an agreement with Kimley-Horn and Associates, Inc. to assist the City’s efforts to create the Plan; and

WHEREAS, beginning in Spring 2017, the City hosted four area-wide public workshops to solicit public input with respect to goals and ideas for Complete Streets; and

WHEREAS, on October 3, 2017, the City hosted a city-wide open house to share the Plan’s initial findings; and

WHEREAS, on December 12, 2018, another city-wide public meeting was held to share the first draft of the Plan with the community; and

WHEREAS, this final draft Plan before the City Council will serve as a long-term vision and blueprint for how St. Petersburg’s street network should be designed and function over the next two decades, which will also be responsive to changing conditions and public engagement in five-year increments; and

WHEREAS, the final draft Plan may require non-substantive edits necessary prior to the publication of the final Plan.

NOW, THEREFORE, BE IT RESOLVED by the City Council of the City of St. Petersburg that this Council hereby approves the final draft of the Complete Streets Implementation Plan ("Plan"), in order to create a comprehensive, integrated, and connected network where Complete Streets are designed and operated to promote safety and accessibility for all users of our roads, trails, and transit systems, including pedestrians, bicyclists, transit riders, motorists, and operators of commercial and emergency vehicles, and people of all ages and physical and economic abilities.

BE IT FURTHER RESOLVED, that it is this City Council's intent to authorize the City Administration to make any non-substantive changes to the attached final draft Plan necessary to publish the final Plan.

This resolution shall become effective immediately upon its adoption.

Adopted at a regular session of the City Council held on the 2<sup>nd</sup> day of May 2019.

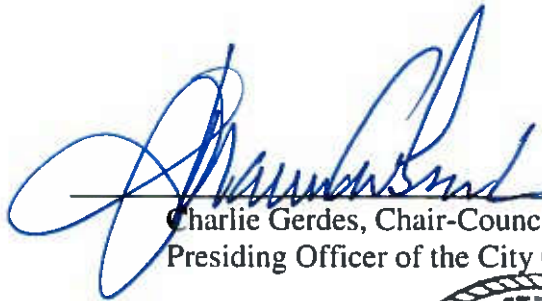

Charlie Gerdes, Chair-Councilmember  
Presiding Officer of the City Council

ATTEST:



Chan Srinivasa, City Clerk



NO. 2015-540

A RESOLUTION SUPPORTING THE COMPLETE STREETS PROGRAM; PROVIDING THAT IT IS THE CITY'S INTENT THAT ALL APPROPRIATE SOURCES OF FUNDING, INCLUDING CITY, COUNTY, STATE AND FEDERAL SOURCES ARE DRAWN UPON TO IMPLEMENT THE COMPLETE STREETS PROGRAM; INSTRUCTING THE CITY CLERK TO TRANSMIT A COPY OF THIS RESOLUTION; AND PROVIDING AN EFFECTIVE DATE.

WHEREAS, the City Vision Statement directly supports the principle that mobility afforded to the individual is basic to the success of the City's land use and transportation system; and

WHEREAS, through implementation of the City's Complete Streets Program, streets are designed and operated to promote safety and accessibility for all users of the transportation network, including pedestrians, bicyclists, transit riders, motorists, commercial and emergency vehicles, and people of all ages and physical and economic abilities; and

WHEREAS, the City has stated its desire for inclusion of a Complete Streets philosophy within the Transportation Mission Statement in the Vision Element of the Comprehensive Plan which states, "St. Petersburg will have a livable balance of connected transportation options for all of its citizens. Pedestrian and bicycle facilities shall be designed, encouraged and celebrated as indicators of a healthy city. Public transit shall be sensitive to the context of neighborhoods and integrated into future economic and development plans"; and

WHEREAS, the City has, through the implementation of the CityTrails Bicycle Pedestrian Master Plan, made significant progress toward development of a pedestrian and bicycle network throughout St. Petersburg that has helped to create a more balanced transportation system that enhances mobility; and

WHEREAS, the City updated its Land Development Regulations to recognize the importance of providing context-sensitive land use planning that supports the desire of the City to improve the balance in the community's mobility as well as to help create unique and long-lasting places; and

WHEREAS, the City recognizes the potential benefits to the local economy and positive transformations that may occur with investments made in implementing Complete Streets; and

WHEREAS, the City has a significant interest in maintaining a sustainable transportation system, and increasing the opportunity for bicycle and pedestrian travel as an alternative to the automobile which reduces the City's reliance on fossil fuels which places the City of St. Petersburg in a position to more effectively reduce greenhouse emissions and improve air quality; and

WHEREAS, St. Petersburg desires to be a city of opportunity whereby the health and wellness of its citizens is considered vital to the overall shared success of the City and a transportation network that considers the needs of all users will be a key component toward providing access to healthy lifestyles; and

WHEREAS, the City desires to complement the efforts by the Florida Department of Transportation (FDOT) that adopted a Complete Streets Policy in September 2014 which states in part that the "Department will routinely plan, design, construct, reconstruct and operate a context-sensitive system of 'Complete Streets'. While maintaining safety and mobility, Complete Streets shall serve the transportation needs of transportation system users of all ages and abilities"; and

WHEREAS, the Pinellas County Transportation Plan includes an endorsement of Complete Streets elements that are similar to those in the FDOT Complete Streets Policy by establishing goals that call for the provision of a balanced and integrated multi-modal transportation system for local and regional travel that enhances quality of life and promotes sustainability.

NOW, THEREFORE, BE IT RESOLVED By the City Council of the City of St. Petersburg that this Council hereby affirms its support of the Complete Streets Program, including City of St. Petersburg Administrative Policy #020400 regarding the Complete Streets Program, which calls for the City of St. Petersburg to continue the development of its transportation system with the intent to create a comprehensive, integrated, and connected network where Complete Streets are designed and operated to promote safety and accessibility for all users of our roads, trails, and transit systems, including pedestrians, bicyclists, transit riders, motorists, and operators of commercial and emergency vehicles, and people of all ages and physical and economic abilities.

BE IT FURTHER RESOLVED, that it is this City Council's intent that all appropriate sources of funding, including City, County, State and Federal sources, are drawn upon to implement the Complete Streets Program.

BE IT FURTHER RESOLVED, that the City Clerk is instructed to transmit a copy of this Resolution to the President of the United States, the United States Senate Majority Leader, the Speaker of the United States House of Representatives, the United States Secretary of Transportation, the State of Florida Department of Transportation Secretary, members of the Pinellas County Legislative Delegation, and the Executive Director of the Pinellas County Metropolitan Planning Organization and Pinellas Planning Council.

This resolution shall become effective immediately upon its adoption.

Adopted at a regular session of the City Council held on the 12th day of November,  
2015.

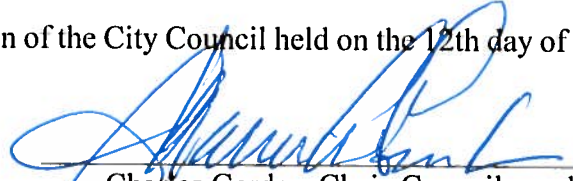

Charles Gerdes, Chair-Councilmember  
Presiding Officer of the City Council

ATTEST:

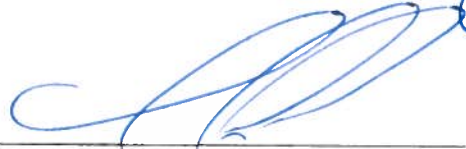

Chan Srinivasa, City Clerk



NO. 2014 -162

A RESOLUTION AUTHORIZING THE MAYOR OR HIS DESIGNEE TO SUBMIT GRANT APPLICATIONS WHICH REQUIRE PRIOR APPROVAL BY CITY COUNCIL FOR SUBMISSION; TO REPRESENT TO THE GRANTOR THAT CITY COUNCIL HAS APPROVED THE SUBMISSION OF THE GRANT APPLICATIONS; AND TO EXECUTE ALL DOCUMENTS NECESSARY TO SUBMIT SUCH GRANT APPLICATIONS; AND PROVIDING AN EFFECTIVE DATE.

WHEREAS, some applications for grants require approval of the application by City Council as a condition for submission of applications; and

WHEREAS, this requirement sometimes creates a shortage of time for preparing and presenting an item for City Council approval in time to meet the grant application deadline; and

WHEREAS, the purpose of this resolution is to provide the Administration with blanket authority to apply for grants to enable the City to meet deadlines for submission of grant applications; and

WHEREAS, acceptance of all grants awarded must be approved by City Council.

NOW THEREFORE, BE IT RESOLVED by the City Council of the City of St. Petersburg, Florida, that the Mayor or his designee is authorized to submit grant applications which require prior approval by City Council for submission; to represent to the grantor that City Council has approved the submission of the grant application; and to execute all documents necessary to submit such grant applications.

This resolution shall become effective immediately upon its adoption.

Adopted at a regular session of the City Council held on the 17th day of April, 2014.

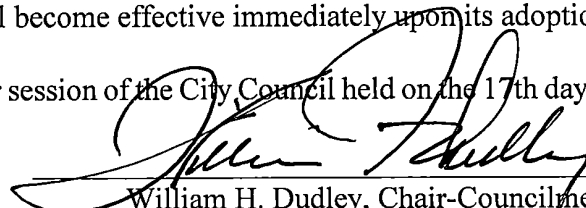
  
William H. Dudley, Chair-Councilmember  
Presiding Officer of the City Council

ATTEST:   
Eva Andujar, City Clerk



## FY23 Capital Improvement Program (CIP)

### HOUSING CAPITAL IMPROVEMENT

|                              |                  |
|------------------------------|------------------|
| Affordable/Workforce Housing | \$675,000        |
| Legal Collection Expense     | <u>25,000</u>    |
| <b>Total Housing</b>         | <b>\$700,000</b> |

### GENERAL CAPITAL IMPROVEMENT

|  |                    |
|--|--------------------|
| Rehab Airfield Vault                         | \$206,122          |
| Replace Federal Contract Tower Equip         | 150,000            |
| MOB Repairs and Improvements                 | 1,015,000          |
| Bay Vista RR ADA Improvements                | 300,000            |
| Williams Park Bandshell Improvements         | 300,000            |
| Pier Head Sound System                       | 180,000            |
| Pier Kiosks for Marketplace                  | 40,000             |
| Pier Shade Shelter for Children's Playground | 200,000            |
| Pier Soil/Drainage Improvements              | 175,000            |
| Pier Splash Pad Resurfacing                  | 50,000             |
| Police CAD/RMS/Mobile System                 | 750,000            |
| Sidewalk Reconstruction                      | 400,000            |
| Sidewalk Master Plan                         | 400,000            |
| Infrastructure TBS                           | <u>1,483,878</u>   |
| <b>Total General Capital</b>                 | <b>\$5,650,000</b> |

### PUBLIC SAFETY CAPITAL IMPROVEMENT

|                                   |                    |
|-----------------------------------|--------------------|
| New Fire Station 2                | \$4,125,000        |
| Public Safety Training Facilities | <u>800,000</u>     |
| <b>Total Public Safety</b>        | <b>\$4,925,000</b> |

### CITYWIDE INFRASTRUCTURE CAPITAL IMPROVEMENT

|   |                     |
|---|---------------------|
| Bicycle Pedestrian Facilities                 | \$100,000           |
| Bridge 2 <sup>nd</sup> St N over Tinney Creek | 625,000             |
| Bridge Venetian Blvd W of Shore Acres         | 3,650,000           |
| Bridge 62 <sup>nd</sup> Avenue S at Maximo    | 125,000             |
| Bridge Life Extension Program                 | 750,000             |
| Bridge Replacement Program                    | 200,000             |
| Affordable Housing Land Acquisitions          | 1,500,000           |
| Neighborhood Partnership Grants               | 75,000              |
| Sanitary Sewer Ann Pipe Repair/Replace.       | 5,000,000           |
| Sanitary Sewer Ann Pipe CIPP Lining           | 4,000,000           |
| Alley and Road Reconstruction - Brick         | 200,000             |
| Alley Reconstruction - Unpaved                | 200,000             |
| Curb/Ramp Reconstruction                      | 400,000             |
| School Zone Upgrades                          | 600,000             |
| Sidewalk Reconstruction                       | 800,000             |
| Street and Road Improvements                  | 4,750,000           |
| <b>Complete Streets</b>                       | <b>450,000</b>      |
| Neighborhood Trans. Management Program        | 100,000             |
| Sidewalks Expansion Program                   | 250,000             |
| Sidewalks-Neighborhood and ADA Ramps          | 250,000             |
| Wayfaring Signage                             | 100,000             |
| Transit Shelter Expansion                     | 200,000             |
| Seawall Renovations and Replacement           | 1,300,000           |
| Transfer Repayment Debt Service               | <u>802,620</u>      |
| <b>Total Citywide Infrastructure</b>          | <b>\$26,427,620</b> |



# FDOT Transportation Alternatives Set-Aside Program

## FUNDING APPLICATION

Submittal Date:

### APPLICANT INFORMATION

|                                  |  |                                 |                               |
|----------------------------------|--|---------------------------------|-------------------------------|
| <b>Agency/Organization Name:</b> |  |                                 |                               |
| <b>Agency Contact Name:</b>      |  | <b>Title:</b>                   |                               |
| <b>Mailing Address:</b>          |  | <b>City:</b>                    | <b>State: FL    Zip Code:</b> |
| <b>County:</b>                   |  | <b>MPO/TPO (if applicable):</b> |                               |
| <b>Telephone:</b>                |  | <b>Email Address:</b>           |                               |

### CERTIFICATION OF PROJECT SPONSOR/IMPLEMENTING AGENCY SUPPORT:

Certification of project sponsor/implementing agency support is attached.

Yes (Required)

**PROJECT TYPE:**  Infrastructure  Non-infrastructure

*FDOT requires locally administered infrastructure projects be implemented by a LAP certified agency; Non-infrastructure projects do not require LAP certification. If the project applicant intends to administer the project but is not LAP certified at the time of application submittal, they may seek project-specific certification prior to project authorization if their application is selected, or they may partner with a LAP certified agency or with FDOT to serve as the project sponsor and implementing agency. Non-profit organizations are not eligible for LAP certification.*

### FOR INFRASTRUCTURE PROJECTS ONLY - APPLICANT'S LOCAL AGENCY PROGRAM (LAP) CERTIFICATION STATUS

- Currently fully LAP Certified / Year of Certification:
- Not LAP Certified but will seek project-specific certification
- Not LAP Certified but project will be administered by the FDOT District
- Not LAP Certified but have secured a LAP Sponsor/Implementing Agency as identified below:

|  |  |                       |                               |
|--|--|-----------------------|-------------------------------|
| <b>LAP Sponsor/Implementing Agency Name:</b>         |  |                       |                               |
| <b>LAP Sponsor/Implementing Agency Contact Name:</b> |  | <b>Title:</b>         |                               |
| <b>Mailing Address:</b>                              |  | <b>City:</b>          | <b>State: FL    Zip Code:</b> |
| <b>Telephone:</b>                                    |  | <b>Email Address:</b> |                               |



## PROJECT INFORMATION

### PROJECT NAME/TITLE:

### ELIGIBLE TRANSPORTATION ALTERNATIVES PROJECT CATEGORY:

Please check the one Transportation Alternatives eligible project category that the proposed project will address. Checking more than one category does not ensure or increase eligibility. Additional guidance on eligible project activities is included in Appendix B of the [FDOT TA Program Guidance](#).

1.  Construction, planning and design of on and off-road facilities for bicyclists, pedestrians, and other forms of nonmotorized transportation (pedestrian and bicycle facilities)
2.  Construction, planning and design of infrastructure-related projects/systems to provide safe routes for non-drivers including children, older adults, individuals with disabilities (safe routes for non-drivers)
3.  Conversion and use of abandoned railroad corridors for non-motorized use
4.  Construction of turnouts, overlooks, and viewing areas
5.  Inventory, control or removal of outdoor advertising
6.  Historic preservation and rehabilitation of historic transportation facilities
7.  Vegetation management practices in transportation rights of way
8.  Archaeological activities related to impacts from transportation projects
9.  Environmental mitigation activities
10.  Safe Routes to School

**\*NOTE:** Safe Routes to School (SRTS) funding under Transportation Alternatives is separate from the FDOT SRTS Program; however, if FDOT SRTS Program funds are to be used on any phase of the project then the project will need to comply with the Florida SRTS program requirements. For more information, visit <https://www.fdot.gov/safety/2A-Programs/Safe-Routes.shtm>.

### PROJECT LOCATION:

|  |   |   |
|--|---|---|
| <b>Roadway name:*</b>  |   |   |
| <input type="checkbox"/> <b>On-State System Road</b><br><small>(State Roadway)</small> | <input type="checkbox"/> <b>Off-State System Road</b><br><small>(Local Roadway)</small> | <b>Roadway number:</b><br><small>(i.e. US, SR, CR, etc., if applicable)</small> |

**\*NOTE:** For off-road/trail projects please indicate adjacent roadway

### PROJECT LIMITS:

If project has various locations (e.g. city-wide), include attachments specifying each termini and project length.

|  |   |
|--|---|
| <b>South or West Termini:</b><br><small>Street Name/Mile Post/Other</small>  | <b>North or East Termini:</b><br><small>Street Name/Mile Post/Other</small> |
| <b>Project Length (in miles):</b>  |   |
| <b>Attachment included?</b> <input type="checkbox"/> Yes <input type="checkbox"/> No   |   |
| <b>A location map with aerial view is attached to this application.</b> <input type="checkbox"/> Yes (Required)<br><i>Label important features, roadways, etc. to clearly locate and show the boundaries of the project.</i> |   |

**PROJECT DESCRIPTION:**

**Brief Description (1,000 character limit)** (e.g. *planning, design and construction of a sidewalk along Sample Road*)

*Detailed Scope of Work:*

A detailed scope of work is attached.

Yes (Required)

*Clearly describe the existing conditions and the proposed project in detail, including specifics on the major items of work (e.g. width of sidewalks or trails, materials to be used, etc.), the purpose and need for this project, and the desired improvements.*

Conceptual or design plans are attached.

Yes  No

Typical Section drawings are attached.

Yes  No

Other attachment (e.g. studies, documentation to support the project).

Yes  No

If yes, please describe (250 character limit):

**PUBLIC INVOLVEMENT(500 character limit for each question below):**

**Has the applicant received input from stakeholders?** Briefly explain:

Yes  No

**Have public information or community meetings been held?**

Yes  No

If yes, please provide a brief description and attach supporting documentation:

**Describe public and private support for the project** (e.g. *petitions, endorsements, resolutions, letters of support*):

**Is the project within limits of wetlands, contamination/hazardous waste areas or endangered/threatened species?**

Yes  No

If Yes, specify and provide documentation:

**Is environmental permitting required?**

Yes  No

If Yes, specify and provide documentation:

**Provide any additional project specific information that should be considered:**

## PROJECT IMPLEMENTATION

**Please indicate the project phases included in this funding request:**

- Planning activities
- Project Development and Environment Study (PD&E)
- Preliminary Engineering/Final Design
- Right-of-Way (ROW)
- Construction
- Construction Engineering and Inspection activities (CEI)

**Please indicate who will execute the project phases identified for this project:\***

| Planning   | PD&E                                    | Preliminary Engineering/<br>Final Design           | ROW                                     | Construction                                       | CEI  |
|--|---|--|---|--|--|
| <input type="checkbox"/> Implementing agency staff | N/A                                     | <input type="checkbox"/> Implementing agency staff | N/A                                     | <input type="checkbox"/> Implementing agency staff | <input type="checkbox"/> Implementing agency staff |
| <input type="checkbox"/> Consultant                | <input type="checkbox"/> Consultant     | <input type="checkbox"/> Consultant                | <input type="checkbox"/> Consultant     | <input type="checkbox"/> Consultant                | <input type="checkbox"/> Consultant                |
| <input type="checkbox"/> FDOT                      | <input type="checkbox"/> FDOT           | <input type="checkbox"/> FDOT                      | <input type="checkbox"/> FDOT           | <input type="checkbox"/> FDOT                      | <input type="checkbox"/> FDOT                      |
| <input type="checkbox"/> Not applicable            | <input type="checkbox"/> Not applicable | <input type="checkbox"/> Not applicable            | <input type="checkbox"/> Not applicable | <input type="checkbox"/> Not applicable            | <input type="checkbox"/> Not applicable            |

**\*NOTE:** Local agencies are not eligible to be certified in PD&E and/or ROW (Refer to FDOT LAP Manual Chapters 11 and 12).

**Is this project related to other FDOT funded phases that are complete, underway, or in FDOT's 5-year Work Program?**

Yes  No

**If Yes, please describe. If previous phases of this project were constructed as LAP projects, please provide the associated FDOT Project Number (i.e. FPID/FMN numbers) (500 character limit):**

**Is there a proposed maintenance plan for when the project is complete?**  Yes  No

If yes, please provide a brief description and attach supporting documentation as appropriate (500 character limit):

## PROJECT RIGHT-OF-WAY / EASEMENT REQUIREMENTS

**Is right-of-way acquisition proposed?**  Yes  No

If yes, describe existing right-of-way (ROW) ownerships along the project, including when the ROW was obtained and how ownership is documented (i.e., plats, deeds, prescriptions, easements) (500 character limit). Attach ROW documentation as appropriate.

Also describe proposed acquisition including timeline, expected fund source, limitations on fund use or availability, and who will acquire and retain ownership of proposed right-of-way (500 character limit):

**Will temporary construction easements be required?**  Yes  No

If Yes, please describe (500 character limit):

## PROJECT COST ESTIMATE AND FUNDING REQUEST

### ESTIMATED PROJECT COST:

A detailed project cost estimate is attached.

Yes (Required)

*Provide a summary of the estimated cost for the work being proposed, indicating local fund allocation as appropriate.*

| Project Phase   | TA funds  | Local funds | Total Cost  |
|---|-----------|-------------|-------------|
| Planning Activities   | \$        | \$          | \$          |
| Project Development & Environmental Study (PD&E)  | \$        | \$          | \$          |
| Design Costs/Plan Preparation   | \$        | \$          | \$          |
| Environmental Assessment (s) associated with the design phase   | \$        | \$          | \$          |
| Permits associated with the design phase (including application fees, mitigation and permit acquisition work) | \$        | \$          | \$          |
| Right-of-Way  | \$        | \$          | \$          |
| Construction  | \$        | \$          | \$          |
| Construction Engineering and Inspection Activities (CEI)  | \$        | \$          | \$          |
| Other costs* (please describe)  | \$        | \$          | \$          |
| <b>TOTAL ESTIMATED PROJECT COST</b>   | <b>\$</b> | <b>\$</b>   | <b>\$</b>   |
| <b>PERCENT OF TOTAL PROJECT COST</b>  |           |             | <b>100%</b> |

*\*FDOT does not allow programming for contingency costs. Any contingency costs should be accounted for using local funds.*



**ENGINEER'S ESTIMATE**  
**FLORIDA DEPARTMENT OF TRANSPORTATION DISTRICT 7**

|                                     |   |
|-------------------------------------|---|
| <b>FINANCIAL PROJECT ID # :</b>     | N/A   |
| <b>PROJECT DESCRIPTION:</b>         | Transportation Alternatives project as part of the Complete Streets Implementation Plan. A demonstration project at 1st Ave S/2nd St N will be modified and implemented at 5th St S and 7th St S. Work includes enhancements to the protected bike line at the intersections. |
| <b>PAY ITEM SPEC YEAR:</b>          | 22-Nov  |
| <b>SUBMITTAL TYPE:</b>              | Preliminary Design Estimate   |
| <b>COUNTY:</b>                      | Pinellas  |
| <b>DATE:</b>                        | November 10, 2022   |
| <b>ENGINEERING CONSULTANT FIRM:</b> | City of St Petersburg   |
| <b>CONTACT NAME:</b>                | Gregory Ashey, P.E.   |
| <b>PHONE NUMBER:</b>                | (727) 893-7851  |
| <b>FILE VERSION:</b>                | EE_01-27_Rev30  |
| <b>PAGE NUMBER:</b>                 | 1 of 5  |

**COMPONENT GROUPS**

|   |                 |                     |
|---|-----------------|---------------------|
| 100 - STRUCTURES                          | <i>NOT USED</i> |                     |
| 200 - ROADWAY                             |                 | \$169,461.00        |
| 300 - SIGNING & PAVEMENT MARKINGS         |                 | \$102,301.18        |
| 400 - LIGHTING                            | <i>NOT USED</i> |                     |
| 500 - SIGNALIZATION                       |                 | \$26,000.00         |
| 550 - ITS                                 | <i>NOT USED</i> |                     |
| 600 - LANDSCAPE / PERIPHERALS             | <i>NOT USED</i> |                     |
| 700 - UTILITIES                           |                 | \$20,000.00         |
| 800 - ARCHITECTURAL                       | <i>NOT USED</i> |                     |
| 900 - MASS TRANSIT                        | <i>NOT USED</i> |                     |
| 1000 - INVALID & OTHER ITEMS              | <i>NOT USED</i> |                     |
| <b>COMPONENT SUB-TOTAL</b>                |                 | \$317,762.18        |
| (102-1) MOT (Maintenance of Traffic)      | 10%             | \$31,776.22         |
| <b>SUB-TOTAL</b>                          |                 | \$349,538.40        |
| (101-1) MOB (Mobilization)                | 10%             | \$31,776.22         |
| <b>SUB-TOTAL</b>                          |                 | \$381,314.62        |
| PU (Project Unknowns)                     | 25%             | \$79,440.55         |
| <b>SUB-TOTAL</b>                          |                 | \$460,755.17        |
| (999-25) Initial Contingency (Do Not Bid) |                 |                     |
| <b>PROJECT GRAND TOTAL</b>                |                 | <b>\$460,755.17</b> |

**NOTES:**

|  |
|--|
| 25% construction cost will be for design fee                         |
| 15% construction cost will be for post design fee                    |
| Total project cost will be the project grand total (above) times 1.4 |
| <b>\$645,057.23</b>  |











## 1<sup>st</sup> Avenue Bikeway Project: Attachments

### Attachments

1. General Location and Project Maps
2. Right of Way Documentation and Maps
3. Concept Drawings
  - a. 1<sup>st</sup> Avenue South and 2<sup>nd</sup> Street
  - b. 1<sup>st</sup> Avenue South and 5<sup>th</sup> Street
  - c. 1<sup>st</sup> Avenue South and 7<sup>th</sup> Street
4. Design Drawings for Interim Improvements at 1<sup>st</sup> Avenue South and 2<sup>nd</sup> Street

General Location and Project Location Maps

Attachment 1a: General Location Map



Attachment 1b: Project Location Map



# Right-of-Way Maps

## Attachment 2A

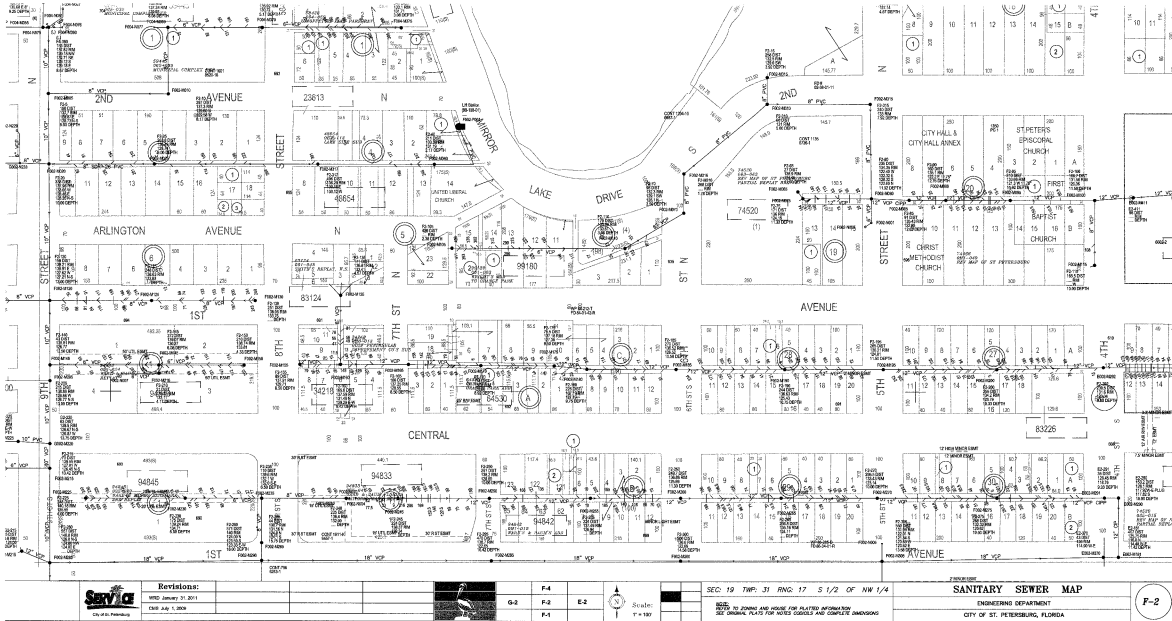

## Attachment 2B

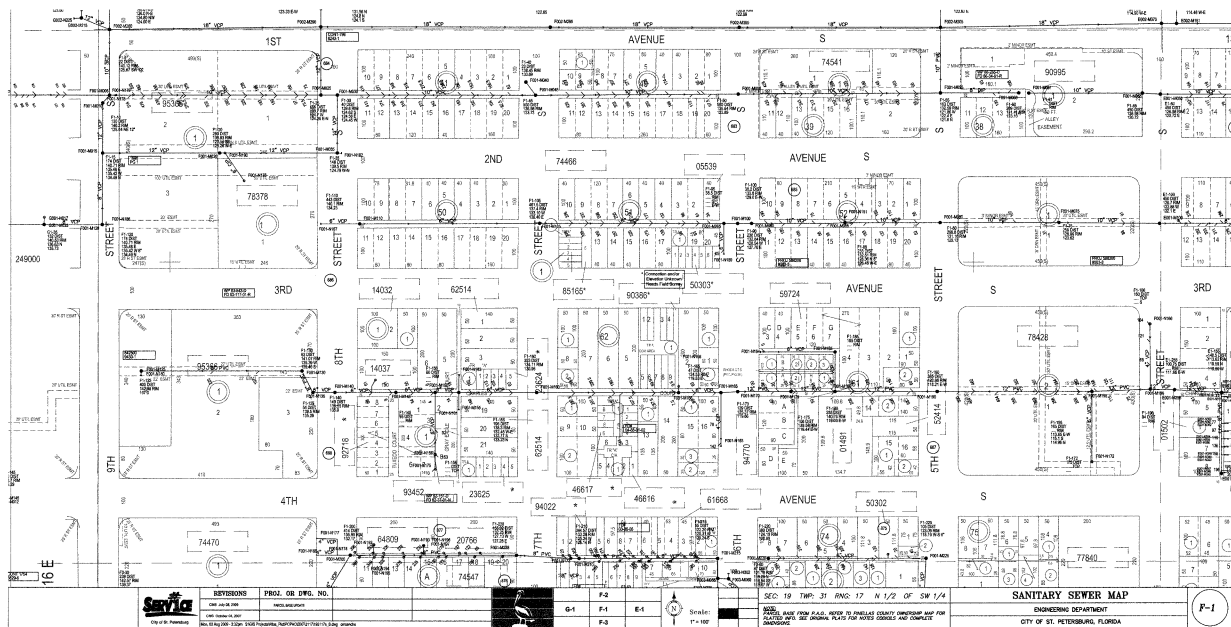

# Right-of-Way Maps

## Attachment 2C

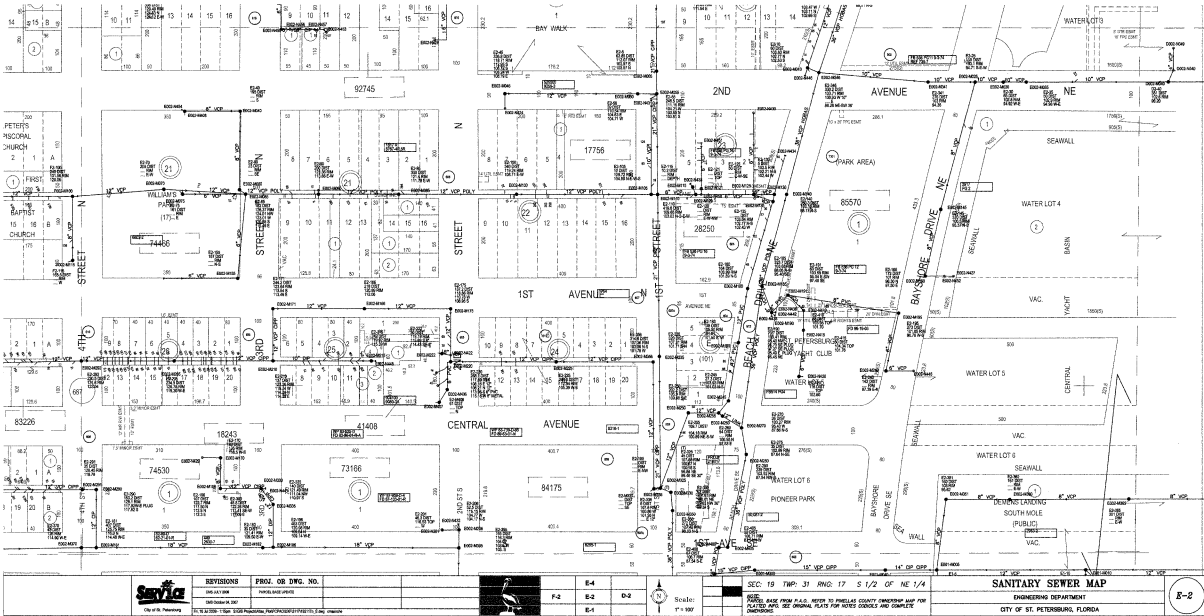

## Attachment 2D

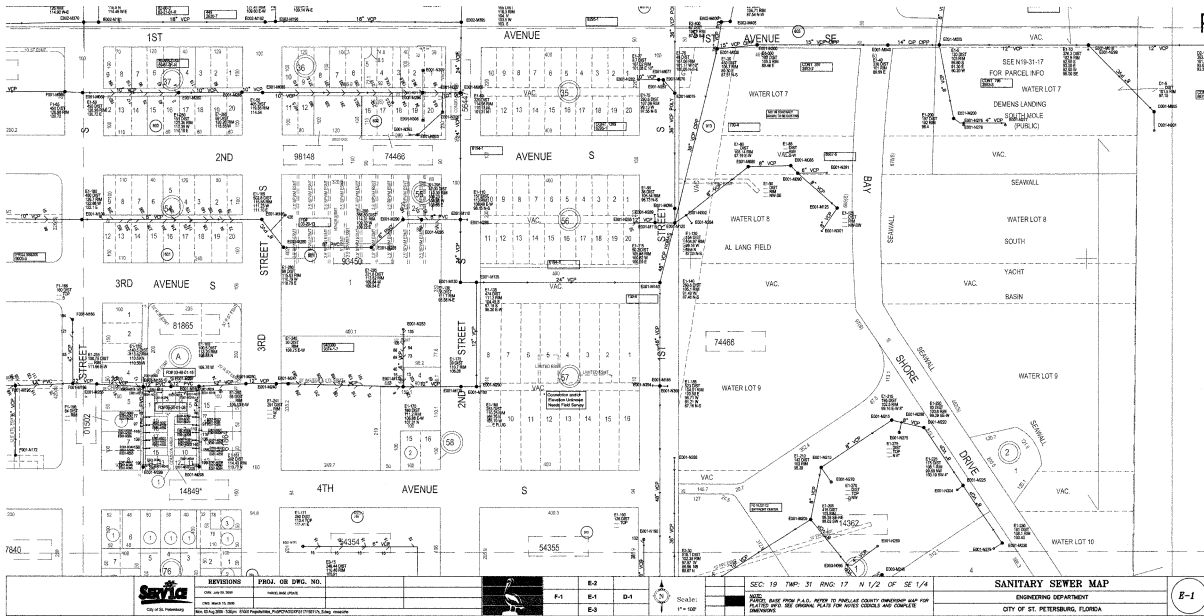

# Concept Drawings

## Attachment 3a.: 1<sup>st</sup> Avenue South and 2<sup>nd</sup> Street

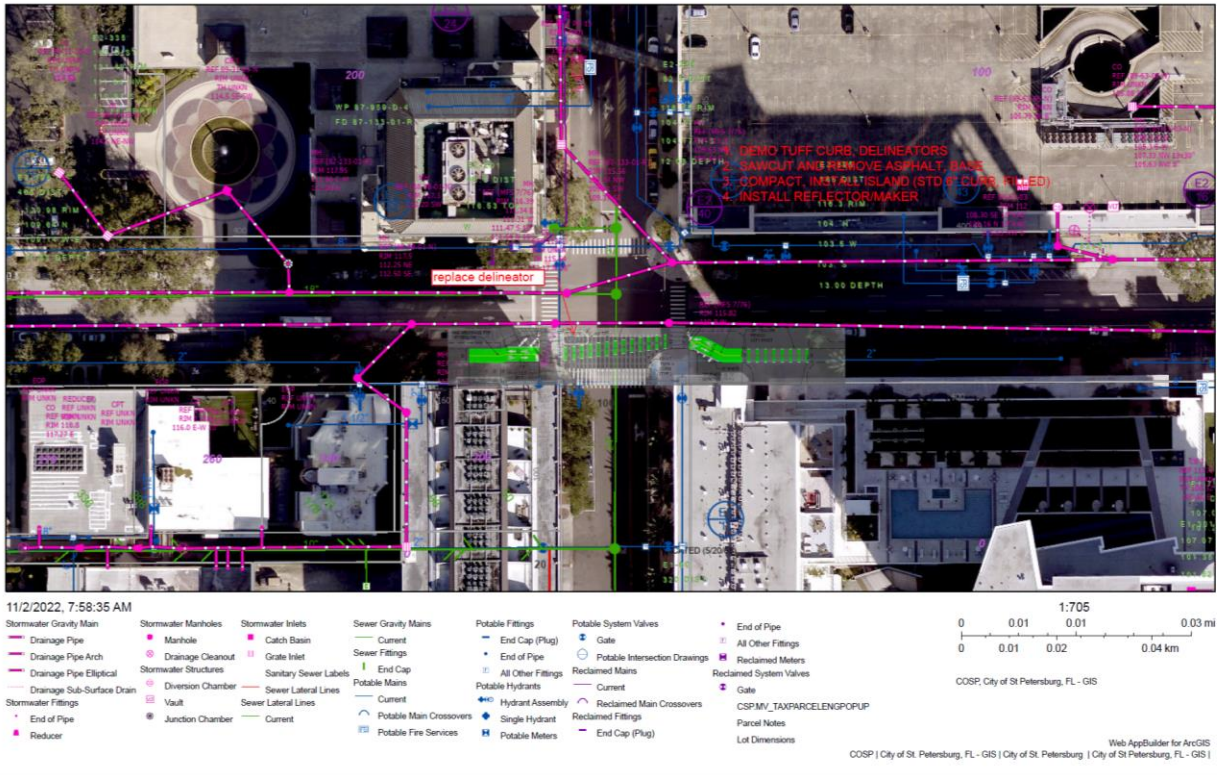

## Attachment 3b: 1<sup>st</sup> Avenue South and 5<sup>th</sup> Street

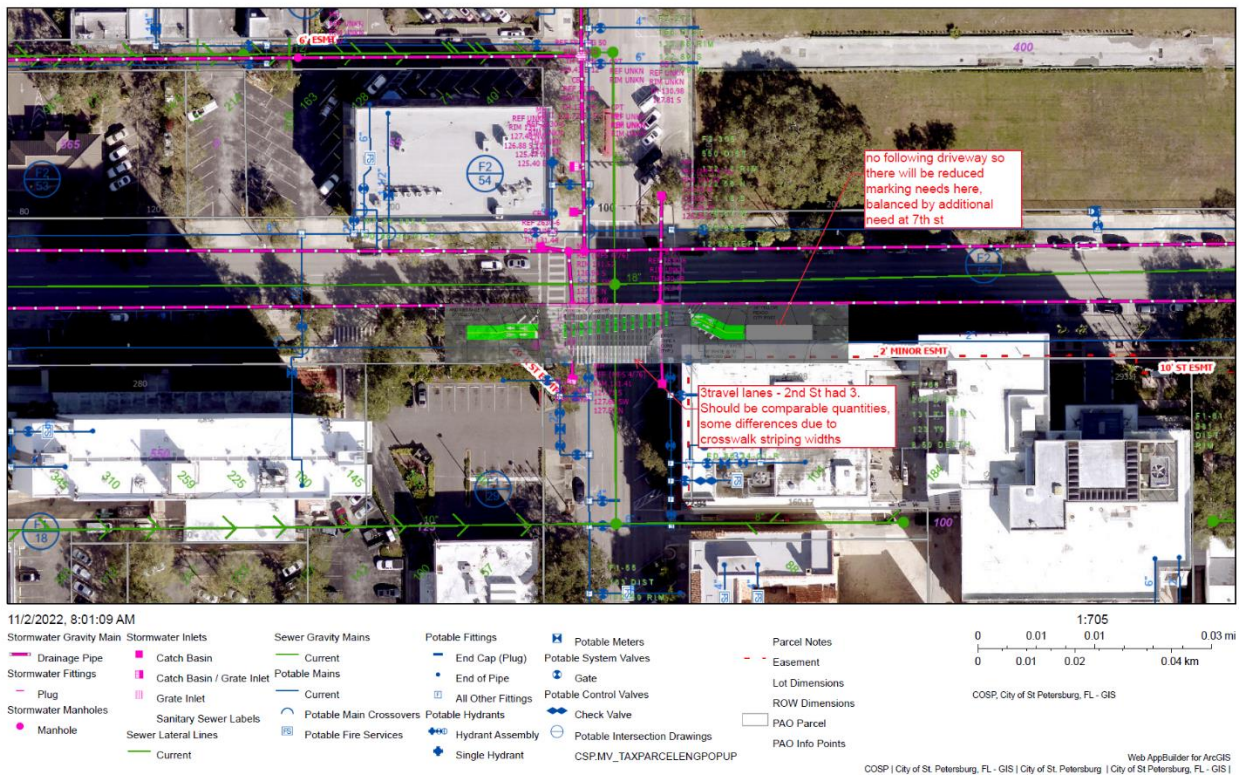

# Concept Drawings

## Attachment 3c: 1st Avenue South and 7th Street

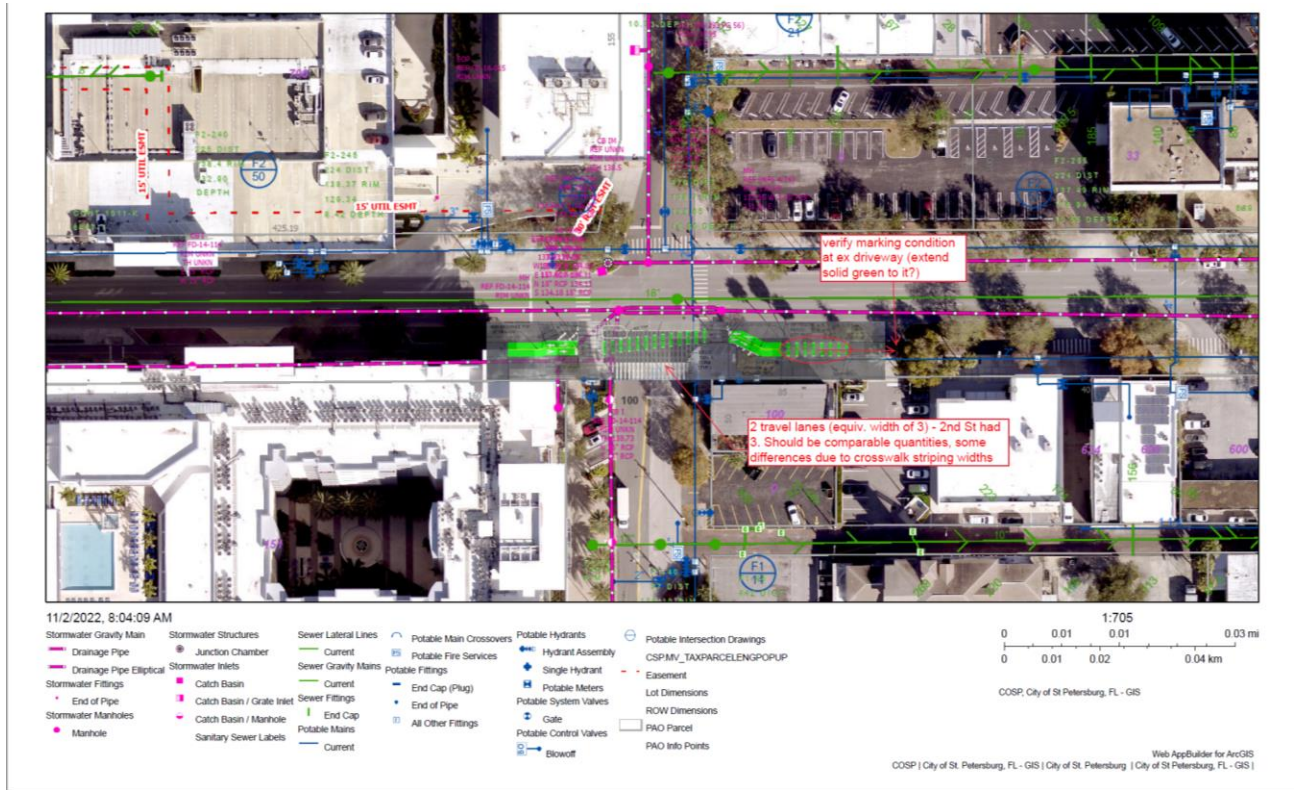



# 1ST AVE S AND 2ND ST S BIKEWAY IMPROVEMENTS

PROJECT NO. 21063-112

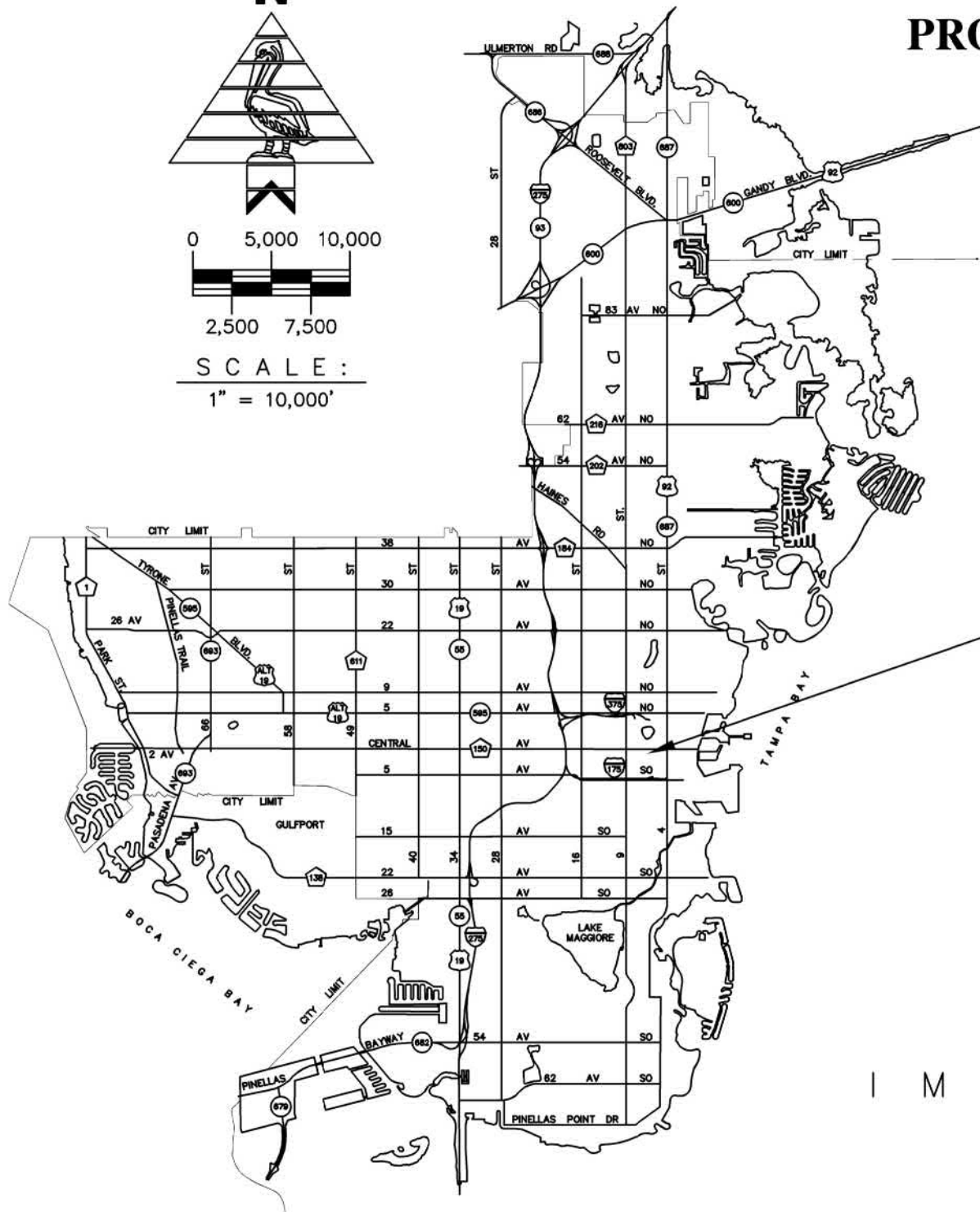
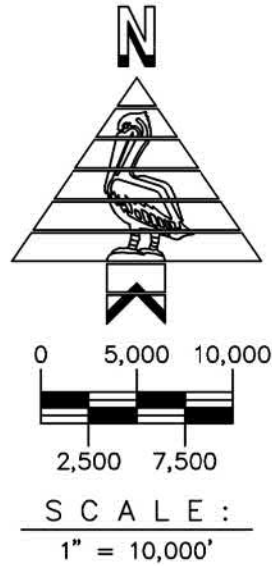

### PROJECT LOCATION

1ST AVE S AND 2ND ST S  
BIKEWAY IMPROVEMENTS

| DRAWING INDEX   |  |
|-----------------|--|
| DRAWING No.     | DESCRIPTION                                |
| -01             | COVER SHEET & INDEX                        |
| -02 THRU -05    | LEGEND, ABBREVIATIONS & GENERAL NOTES      |
| -06             | SITE PLAN                                  |
|                 | 2020-21 FDOT STANDARD PLANS DETAILS        |
| 711-002         | BICYCLE MARKINGS                           |
|                 | 2020-21 FDOT DEVELOPMENTAL SPECIFICATIONS  |
| DEV 311         | SAND SEAL COAT                             |
| DEV 703CC       | CHANNELIZING CURB                          |
| DEV 705LBD      | OBJECT MARKERS AND DELINEATORS             |
| DEV 714GCPM     | GREEN - COLORED PAVEMENT MARKINGS          |
| DEV 976GCPM     | GREEN - COLORED PAVEMENT MARKING MATERIALS |
| DEV 993LBD      | OBJECT MARKERS AND DELINEATORS             |
|                 | API/IPL DRAWINGS AND SPECIFICATIONS        |
| APL 120-025-010 | IRS TUFF CURB XLP                          |
| IPL SECTION 993 | PEXCO SURFACE MOUNT CITY POST              |

#### PLANS PREPARED BY:

DANIEL A. CARNLEY  
P.E. NO.: 75529  
WSP USA INC.  
2202 N. WEST SHORE BLVD., SUITE 300  
TAMPA, FL 33607

ENGINEERING & CAPITAL  
IMPROVEMENTS DEPARTMENT  
CITY of ST. PETERSBURG, FL.

DATE

BREJESH PRAYMAN, P.E.  
DIRECTOR OF ENGINEERING & CAPITAL  
IMPROVEMENTS DEPARTMENT

DATE: 07/21

DRAWING No. 11523-01

### PLOTTING SYMBOLS

| APPLICATION                 | EXISTING       | PROPOSED               |
|-----------------------------|----------------|------------------------|
| APPROXIMATE                 | ±              | ±                      |
| BENCH MARK, CITY CONTROLLED | ⊕ CBM #XXX     | ⊕ CBM #XXX             |
| BENCH MARK, TEMPORARY       | ⊠ TBM-BOX CUT  | ⊠ TBM-BOX CUT          |
| BORING SITE                 | ⊕              | ⊕                      |
| BUSH                        | ⊙              | N/A                    |
| CENTERLINE                  | ⊕ OR C/L       | ⊕ OR C/L               |
| CONCRETE MONUMENT           | ⊠ C.M.         | ⊠ C.M.                 |
| DELTA ANGLE                 | △              | △                      |
| FOUND CONCRETE MONUMENT     | ⊠ F.C.M.       | N/A                    |
| FOUND IRON PIPE             | ⊙ FIP          | N/A                    |
| FOUND IRON ROD              | ⊙ FIR          | N/A                    |
| FOUND "X" CUT               | ⊗ FND. "X" CUT | N/A                    |
| NORTH ARROW                 | N/A            | ⊕                      |
| OVERLAND FLOW ARROW         |                |                        |
| REVISION                    | ⚠              | ⚠ REVISION DESCRIPTION |
| SURVEY BASELINE             | ⊕ OR B/L       | ⊕ OR B/L               |
| SURVEY NAIL AND DISK        | ⊙ S.D.         | N/A                    |
| SURVEY TRAVERSE POINT       | △              | N/A                    |

### GENERAL LINSTYLES

| APPLICATION                                       | EXISTING | PROPOSED |
|---|----------|----------|
| BASE LINE OF SURVEY                               |          |          |
| BUILDING WALL                                     |          |          |
| CENTER LINE OF CONSTRUCTION                       | N/A      |          |
| FENCE, LABEL HEIGHT AND TYPE                      |          |          |
| GUARD RAIL  |          |          |
| HEDGE LINE, LABEL TYPE AND HEIGHT                 |          |          |
| TOP OF BANK                                       |          |          |
| TREE OR WOOD LINE, LABEL TYPE AND DIAMETER AT DBH |          |          |

### UTILITY LINSTYLES

| APPLICATION         | EXISTING | PROPOSED |
|---------------------|----------|----------|
| CABLE TV, BURIED    |          | N/A      |
| CABLE TV, OVERHEAD  |          | N/A      |
| FIBER OPTICS CABLE  |          | N/A      |
| FORCE MAIN          |          |          |
| GAS MAIN            |          | N/A      |
| POWER, BURIED       |          | N/A      |
| POWER, OVERHEAD     |          | N/A      |
| RECLAIMED WATER     |          |          |
| SANITARY SEWER      |          |          |
| STORM DRAIN         |          |          |
| TELEPHONE, BURIED   |          | N/A      |
| TELEPHONE, OVERHEAD |          | N/A      |
| UNDERDRAIN          |          |          |
| WATER MAIN          |          |          |

### PRESSURE PIPE SYMBOLS

| APPLICATION            | EXISTING | PROPOSED |
|------------------------|----------|----------|
| AIR RELEASE            |          |          |
| HYDRANT                |          |          |
| HYDRANT & VALVE        |          |          |
| METER, RECLAIMED WATER |          |          |
| METER, WATER           |          |          |
| PLUG                   |          |          |
| REDUCER                |          |          |
| TAP VALVE & SLEEVE     |          |          |
| TEE                    |          |          |
| VALVE                  |          |          |
| VALVE W/BLOW OFF       |          |          |

### UTILITY POLE SYMBOLS

| APPLICATION     | EXISTING | PROPOSED |
|-----------------|----------|----------|
| GUY WIRE/ANCHOR |          |          |
| JOINT USER POLE |          |          |
| LIGHT POLE      |          |          |
| POWER POLE      |          |          |
| TELEPHONE       |          |          |

### STRUCTURE SYMBOLS

| APPLICATION          | EXISTING | PROPOSED |
|----------------------|----------|----------|
| MANHOLE, CLEAN OUT   |          |          |
| MANHOLE, ELECTRIC    |          |          |
| MANHOLE, GAS         |          |          |
| MANHOLE, SEWER       |          |          |
| MANHOLE, STORM DRAIN |          |          |
| MANHOLE, TELEPHONE   |          |          |
| METER, GAS           |          |          |

**A**

ABD ABANDONED  
 AC ACRE  
 ALT ALTERNATE  
 APPROX APPROXIMATE  
 ASPH ASPHALT  
 ASPH CONC ASPHALTIC CONCRETE  
 AVE AVENUE

**B**

BBM BRIDGE BENCH MARK  
 BC BOX CULVERT  
 B/C BACK OF CURB  
 BEG BEGIN  
 BLDG BUILDING  
 BLVD BOULEVARD  
 BM BENCH MARK  
 B.O. BLOW-OFF  
 BOT BOTTOM  
 BFV BUTTERFLY VALVE  
 B/W BACK OF WALK  
 B/L OR  $\text{B}$  BASELINE OF SURVEY

**C**

C AND G CURB AND GUTTER  
 CB CATCH BASIN  
 CBM CITY BENCH MARK  
 CF CUBIC FEET  
 CI CURB INLET  
 CIP CAST IRON PIPE  
 CIPL CAST-IN-PLACE  
 CL CLEARANCE  
 C/L OR  $\text{C}$  CENTERLINE OF CONSTRUCTION  
 CLF CHAIN LINK FENCE  
 CM CONCRETE MONUMENT  
 CPP CORRUGATED PLASTIC PIPE  
 CMP CORRUGATED METAL PIPE  
 CMPA CORRUGATED METAL PIPE ARCH  
 CO COUNTY OR CLEAN-OUT  
 CONC CONCRETE  
 CONST CONSTRUCT  
 CORR CORRUGATED  
 CP CONCRETE PIPE  
 CSP CORRUGATED STEEL PIPE  
 CTR CENTER  
 CULV CULVERT  
 CY CUBIC YARD

**D**

DBL DOUBLE  
 DEPT DEPARTMENT  
 DI DROP INLET or DUCTILE IRON  
 DIA DIAMETER  
 DIM DIMENSION  
 DIP DUCTILE IRON PIPE

**D (CONT.)**

DISP DISPOSAL  
 DOT DEPARTMENT OF TRANSPORTATION  
 DR DRAIN  
 D/W DRIVEWAY  
 DWG DRAWING

**E**

E EAST  
 EA EACH  
 EL OR ELEV ELEVATION  
 ELEC ELECTRIC  
 EP EDGE OF PAVEMENT  
 ESMT EASEMENT  
 E.W. OR E/W EACHWAY  
 EXIST EXISTING

**F**

FCM FOUND CONCRETE MONUMENT FIRE  
 FH HYDRANT  
 FIP FOUND IRON PIPE  
 FIR FOUND IRON ROD  
 FL FLOW LINE  
 F.M. FORCE MAIN  
 F/C FACE OF CURB

**G**

GALV GALVANIZED  
 GI GRATE INLET  
 GSP GALVANIZED STEEL PIPE  
 GR GRADE  
 GRND GROUND  
 GUT OR GTTR GUTTER  
 GV GATE VALVE

**H**

HDPE HIGH DENSITY POLYETHYLENE PIPE  
 HDWL HEADWALL  
 HNDRL HANDRAIL  
 HP HW HIGH POINT HIGH WATER  
 HWY HIGHWAY  
 HYD HYDRANT

**I**

IP IRON PIPE  
 INSTL INSTALL  
 INV INVERT

**J**

JB JUNCTION BOX

**L**

LF LINEAR FEET

**M**

(M) MEASURED DISTANCE  
 MAX MAXIMUM  
 MES MITERED END SECTION  
 MH MANHOLE  
 MHW MEAN HIGH WATER  
 MIN MINIMUM  
 MISC MISCELLANEOUS  
 MLW MEAN LOW WATER  
 MON MONUMENT  
 MPH MILES PER HOUR  
 MSL MEAN SEA LEVEL

**N**

N/A NOT APPLICABLE  
 N NORTH  
 NE NORTHEAST  
 NGVD NATIONAL GEODETIC VERTICAL DATUM  
 NIC NOT IN CONTRACT OR NOT INCLUDED  
 NW NORTHWEST

**O**

OC ON CENTER  
 OVHD OVERHEAD

**P**

(P) PLAT  
 PAVT/PVMT PAVEMENT  
 PC POINT OF CURVATURE  
 PI POINT OF INTERSECTION  
 PP POWER POLE  
 PVC POLYVINYL CHLORIDE  
 PVI POINT OF VERTICAL INTERSECTION  
 P/L OR  $\text{P}$  PROPERTY LINE

**R**

R RADIUS  
 RCP REINFORCED CONCRETE PIPE  
 RCWM RECLAIMED WATER MAIN  
 RD ROAD  
 RDWY ROADWAY  
 RR OR R/R RAILROAD  
 R/W RIGHT-OF-WAY

**S**

S SOUTH  
 SAN SANITARY  
 SD STORM DRAIN  
 SE SOUTHEAST  
 SECT SECTION  
 SEW SEWER  
 SF OR SQ FT SQUARE FOOT OR SQUARE FEET

**S (CONT.)**

SI OR SQ IN SQUARE INCH  
 SPEC SPECIFICATION  
 SY OR SQ YD SQUARE YARD  
 SR STATE ROAD  
 ST STREET  
 STA STATION  
 STD STANDARD  
 SW SOUTHWEST  
 S/W SIDEWALK

**T**

T TANGENT  
 TBM TEMPORARY BENCH MARK  
 T.O.B. TOP OF BANK  
 T/C OR TOC TOP OF CURB  
 TEL TELEPHONE  
 TWP TOWNSHIP  
 TYP TYPICAL

**U**

UD UNDERDRAIN  
 UG UNDERGROUND

**V**

VAR VARIES OR VARIOUS  
 VC VERTICAL CURVE  
 VF VERTICAL FOOT OR VERTICAL FEET  
 VCP VITRIFIED CLAY PIPE  
 VERT VERTICAL

**W**

W WEST  
 WM WATER MAIN  
 WT WATER TABLE, WEIGHT, OR WALL

| ITEM | BY | REMARKS | NAME           | DATE | REVISIONS | BY | DATE |
|------|----|---------|----------------|------|-----------|----|------|
|      |    |         | DESIGNED BY:   | KR   | 7/21      |    |      |
|      |    |         | DRAWN BY:      | RB   | 7/21      |    |      |
|      |    |         | CHECKED BY:    | CR   | 7/21      |    |      |
|      |    |         | SUPERVISED BY: | DC   | 7/21      |    |      |

|  |               |  |   |   |
|--|---------------|--|---|---|
| Prepared By:<br>DANIEL A. CARNLEY<br>P.E. NO.: 75529<br>WSP USA INC.<br>2202 N. WEST SHORE BLVD., SUITE 300<br>TAMPA, FL 33607 | ABBREVIATIONS |  ENGINEERING & CAPITAL<br>IMPROVEMENTS DEPARTMENT<br>CITY OF ST. PETERSBURG<br>CITY PROJECT MANAGER:<br>EVAN BIRK, P.E. | 1ST AVE S AND 2ND ST S<br>BIKEWAY IMPROVEMENTS<br>21063-112 | DATE: 7/15/21<br>SCALE: NTS<br>DRAWING No.<br>1152-03 |
|--|---------------|--|---|---|

GENERAL NOTES

- 1. THE LOCATIONS(S) OF THE UTILITIES SHOWN IN THE PLANS ARE BASED ON LIMITED INVESTIGATION TECHNIQUES AND SHOULD BE CONSIDERED APPROXIMATE ONLY. THE VERIFIED LOCATIONS / ELEVATIONS APPLY ONLY AT THE POINT SHOWN. INTERPOLATIONS BETWEEN THESE POINTS HAVE NOT BEEN VERIFIED. UTILITIES SHALL REMAIN UNLESS OTHERWISE NOTED.
2. THE CONTRACTOR SHALL CALL THE SUNSHINE STATE ONE CALL OF FLORIDA, INC. AT 811 OR 1-800-432-4770 AND THE UTILITY OWNERS 48 HOURS BEFORE BEGINNING WORK. ALL UTILITY OWNERS MAY NOT BE A MEMBER, REQUIRING DIRECT CONTACT.
3. THE CONTRACTOR IS TO MAINTAIN AND KEEP STREET NAME IDENTIFICATION VISIBLE DURING CONSTRUCTION OPERATIONS, IN ORDER TO FACILITATE EMERGENCY VEHICLE TRAFFIC.

THE CONTRACTOR IS HEREBY NOTIFIED THAT ABOVE GROUND OR UNDERGROUND UTILITIES MAY BE IN THE AREA OF THIS PROJECT AND ARE TO BE ADJUSTED BY OTHERS AS DIRECTED BY THE ENGINEER. THE CONTRACTOR IS RESPONSIBLE FOR UTILITY COORDINATION.

Table with columns: UTILITY OWNERS: COMPANY, CONTACT, TELEPHONE NUMBERS. Lists utility owners like BLACK & VEACH TAMPA, CENTURYLINK, CHARTER COMMUNICATIONS, etc.

Table with columns: CITY OF ST. PETERSBURG: WATER RESOURCES, ENG. CONST., STORMWATER/TRANSPORTATION OPS, etc. Lists contact info for various city departments.

- 4. THE CONTRACTOR SHALL SECURE THE NECESSARY PERMITS/RIGHT OF ENTRY FROM THE CITY OF ST. PETERSBURG FOR ANY WORK WITHIN THE CITY'S RIGHT-OF-WAY AND EASEMENTS. (THE LIST WILL BE AVAILABLE AT THE PRE-CONSTRUCTION MEETING.) THE CONTRACTOR SHALL ALSO NAME THE CITY OF ST. PETERSBURG AS ADDITIONAL PARTY TO THE INSURANCE COVERAGE.
5. ALL PROPOSED FACE OF CURB SHALL MATCH THE EXISTING FACE OF CURB, UNLESS OTHERWISE SHOWN ON PLANS.
6. TREES WITHIN THE LIMITS OF THIS PROJECT THAT ARE TO REMAIN SHALL BE TRIMMED TO CONFORM TO SECTION 110, APPLICABLE ADA REQUIREMENTS AND FLORIDA DESIGN MANUAL SECTION 212.11. COST TO BE INCLUDED IN STANDARD CLEARING AND GRUBBING.
7. ALL DISTURBED AREAS, INCLUDING AREAS OUTSIDE THE CONSTRUCTION LIMITS, SHALL BE RETURNED TO THEIR PRE-CONSTRUCTION CONDITIONS AT THE CONTRACTORS EXPENSE. GRASS AREAS SHALL BE SODDED, NOT SEEDED AND MULCHED.
8. THE CONTRACTOR SHALL PROVIDE AND IMPLEMENT SITE SPECIFIC EROSION AND SEDIMENT CONTROL PROCEDURES SUCH AS SYNTHETIC BALES, STAKED SILT BARRIERS, FLOATING TURBIDITY BARRIER, OR OTHER APPROVED METHODS AS REQUIRED TO PREVENT THE TRANSPORTATION OF SEDIMENT DOWNSTREAM INTO STREETS, STORM DRAINS, DITCHES, PONDS, ETC.
9. ALL EXISTING CITY TRAFFIC SIGNS WITHIN THE PROPOSED CONSTRUCTION LIMITS ARE TO BE PROTECTED BY THE CONTRACTOR. CAUTION SHOULD BE EXERCISED WHILE RELOCATING EXISTING SIGNS WHERE DIRECTED. IF THE SIGNS ARE DAMAGED BEYOND USE, AS DETERMINED BY THE ENGINEER, THE DAMAGED SIGNS SHALL BE REPLACED AT THE CONTRACTORS EXPENSE.
10. THE CONTRACTOR SHALL COMPLY WITH THE OSHA 20FT RULE; 29 CFR 1926.
11. THE CONTRACTOR SHALL NOTIFY THE PROPERTY OWNERS, 48 HOURS IN ADVANCE OF CONSTRUCTION ACTIVITIES. THE CONTRACTOR SHALL NOT RESTRICT ACCESS, DELIVERY, ETC. TO THE PROPERTIES AND SHALL MAINTAIN A SAFE AND DIRECT ACCESS AT ALL TIMES.
12. ALL FIELD LAYOUT AND SURVEYING FOR CONSTRUCTION OF THIS PROJECT SHALL BE PROVIDED BY THE CONTRACTOR AT HIS EXPENSE UNDER THE DIRECTION OF A LICENSED PROFESSIONAL LAND SURVEYOR.
13. VERTICAL CONTROL IS BASED UPON THE CITY OF ST. PETERSBURG DATUM ELEVATION OF 97.00, WHICH IS EQUAL TO 00.00 N.G.V.D. (1929)
14. THE CONTRACTOR SHALL GIVE WRITTEN NOTICE TO ALL AFFECTED CITY WATER CUSTOMERS A MINIMUM OF 24 HOURS IN ADVANCE OF ANY AND ALL WORK REQUIRING DISRUPTION OF ACCESS, INTENDED WATER, OR SANITARY SEWER SERVICE INTERRUPTION. DISRUPTION IN SERVICE TO ANY CUSTOMER SHALL NOT EXCEED 2 HOURS FOR WATER AND 4 HOURS FOR SANITARY SEWER SERVICE. ACCESS TO PROPERTY SHALL BE MAINTAINED AT ALL TIME.
15. IT SHALL BE THE RESPONSIBILITY OF THE CONTRACTOR TO SHAPE THE PAVEMENT AT INTERSECTIONS, STREETS, AND DRIVEWAYS SO THAT POSITIVE DRAINAGE WILL BE MAINTAINED WITH NO PONDING OF WATER AS A RESULT OF THE NEW CONSTRUCTION.
16. THE CONTRACTOR SHALL ADJUST (AS REQUIRED) PIPELINE ALIGNMENTS HORIZONTALLY AND/OR VERTICALLY TO AVOID CONFLICTS WITH ACTUAL FIELD CONDITIONS AS UNCOVERED DURING CONSTRUCTION. FIELD ADJUSTMENT SHALL BE COORDINATED WITH, AND APPROVED BY, THE ENGINEER IN WRITING PRIOR TO REALIGNMENT.
17. THE CONTRACTOR SHALL PROVIDE ALL DEWATERING EQUIPMENT NECESSARY TO KEEP EXCAVATIONS DRY AND SHALL PROVIDE ALL SHORING, SHEETING, AND BRACING NECESSARY TO PROTECT WORKMEN, ADJACENT STRUCTURES, UTILITES, EXISTING PAVEMENT, OR TO MINIMIZE TRENCH WIDTH, AT THE CONTRACTORS EXPENSE.
18. EXISTING SUBSURFACE UTILITY HORIZONTAL ALIGNMENTS WERE ESTABLISHED THROUGH THE USE OF AVAILABLE RECORDS AND THEREFORE, ARE SHOWN IN THERE APPROXIMATE LOCATIONS. THE CONTRACTOR SHALL NOTIFY THE RESPECTIVE UTILITY COMPANIES NO LATER THAN 48 HOURS PRIOR TO COMMENCING WORK IN A SPECIFIC AREA. THE CONTRACTOR SHALL BE RESPONSIBLE FOR THE VERIFICATION OF ALL UTILITY LOCATIONS WITHIN THE WORK AREA.
19. ATTENTION IS DIRECTED TO THE FACT THAT SOME PORTIONS OF STORM DRAIN DRAINAGE STRUCTURES OR STORM DRAIN PIPES EXTEND INTO THE STABILIZED PORTION OF THE ROADWAY. EXTREME CAUTION SHOULD BE UTILIZED DURING STABILIZATION OPERATIONS AT THESE LOCATIONS. ADDITIONAL COMPACTED BASE MATERIAL MAY BE REQUIRED AT THE DIRECTION OF THE

- ENGINEER.
20. SEE SPECIFICATIONS FOR REQUIREMENTS IN ADDITION TO GENERAL NOTES.
21. CONTRACTOR SHALL NOTIFY OWNER OF ANY DISCREPANCIES BETWEEN NOTES, PLANS, AND/OR SPECS DURING BIDDING DISCREPANCIES WILL BE RESOLVED BY THE ENGINEER.
22. ALL WORK SHALL CONFORM TO THE REQUIREMENTS OF THESE PLANS, THE SPECIFICATIONS, AND CONTRACT DOCUMENTS.
23. CONTRACTOR SHALL VERIFY ALL DIMENSIONS AND EXISTING CONDITIONS BEFORE STARTING WORK, NOTIFY ENGINEER OF DISCREPANCIES.
24. ALL SAFETY REGULATIONS ARE TO BE STRICTLY FOLLOWED. METHODS OF CONSTRUCTION AND ERECTION OF STRUCTURAL MATERIAL IS THE CONTRACTORS RESPONSIBILITY.
25. ALL VERTICAL CONTROL POINTS AND TEMPORARY BENCHMARKS, WHETHER SHOWN ON THE PLANS OR SET BY THE CONTRACTOR, SHALL BE RE-ESTABLISHED FROM THE CITY OF ST. PETERSBURG'S STANDARD BENCHMARK SYSTEM. COMPLIANCE WITH THIS ACTIVITY SHALL BE DOCUMENTED IN THE SURVEYORS FIELD NOTES, A COPY OF WHICH SHALL BE PROVIDED TO THE ENGINEER.
26. SPECIFIC REQUIREMENTS OF THE CITY OF ST. PETERSBURG CONTRACT SPECIFICATIONS AND STANDARDS ARE INCORPORATED INTO CONTRACT DOCUMENTS BY REFERENCE.
27. SPECIFIC REQUIREMENTS OF THE FLORIDA DEPARTMENT OF TRANSPORTATION'S STANDARD PLANS AND STANDARD SPECIFICATIONS FOR ROAD AND BRIDGE CONSTRUCTION ARE INCORPORATED INTO CONTRACT DOCUMENTS BY REFERENCE.
28. ALL SPECIFICATION AND DOCUMENTS REFERRED TO SHALL BE OF LATEST REVISIONS AND/OR LATEST EDITION.
29. CONTRACTOR SHALL PROTECT PROPERTY MARKERS, MONUMENTS AND TEMPORARY BENCHMARKS. THE CONTRACTOR'S REGISTERED SURVEYOR SHALL REPLACE TO EXISTING OR BETTER CONDITION ANY DISTURBED PROPERTY MARKERS, MONUMENTS AND TEMPORARY BENCHMARKS.
30. ANY UNITED STATES COAST AND GEODETIC SURVEY (USC&GS) MONUMENT WITHIN LIMITS OF CONSTRUCTION IS TO BE PROTECTED. IF IN DANGER OF DAMAGE, THE CONTRACTOR SHALL NOTIFY THE ENGINEER IMMEDIATELY AND CONTACT THE GEODETIC INFORMATION CENTER ATTN.: MARK MAINTENANCE CENTER ATTN: N/CG-162 6001 EXECUTIVE BLVD. ROCKVILLE, MARYLAND 20852 (301) 443-8319.
31. THE CONTRACTOR SHALL MAINTAIN COPIES OF ALL APPLICABLE PERMITS ON-SITE AND SHALL BE RESPONSIBLE TO ADHERE TO ALL PERMIT CONDITIONS DURING CONSTRUCTION.
32. PAYMENT FOR INCIDENTAL ITEMS NOT SPECIFICALLY LISTED IN THE INDIVIDUAL BID ITEMS SHALL BE INCLUDED IN THE CONTRACT PRICES FOR BID ITEMS SHOWN.
33. THE CONTRACTOR SHALL PROVIDE, ERECT, AND MAINTAIN BARRICADES, DANGER SIGNALS, AND SIGNS IN ALL AREAS WHERE REQUIRED FOR THE PROTECTION OF THE WORK AND SAFETY OF THE PUBLIC.
34. ANY DAMAGE TO CITY, COUNTY OR STATE ROADS CAUSED BY THE CONTRACTOR'S HAULING OF EXCAVATION EQUIPMENT OR MATERIALS SHALL BE REPAIRED BY THE CONTRACTOR IN A TIMELY MANNER AND TO THE SATISFACTION OF THE ENGINEER. PAYMENT SHALL NOT BE MADE FOR THIS WORK.
35. THE CONTRACTOR SHALL ENDEAVOR TO PROTECT PRIVATE PROPERTY. ANY DAMAGE CAUSED BY THE CONTRACTOR IN THE PERFORMANCE OF HIS WORK SHALL BE CORRECTED TO THE SATISFACTION OF THE ENGINEER IN A TIMELY MANNER. PAYMENT SHALL NOT BE MADE FOR THIS WORK.
36. UPON COMPLETION OF CONCRETE WORK, DEWATERING SHALL BE TERMINATED GRADUALLY TO AVOID RAPID UPWARD MOVEMENT OF GROUND WATER.
37. MUCK/ORGANIC SOILS ENCOUNTERED DURING EXCAVATION SHALL BE STOCKPILED SEPARATELY AND PROTECTED FROM WEATHER CONDITIONS FOR USE AS SUBSTRATE IN PLANTING AREAS.
38. THE CONTRACTOR SHALL PLACE CONSTRUCTION DEBRIS CONTROL DEVICES, BOOMS, TARPULINS, FLOATS, STAGING, AND OTHER DEVICES AS NECESSARY AS TO PREVENT CONSTRUCTION DEBRIS FROM ENTERING THE WATER, AND AIR BORNE MATERIALS FROM LEAVING THE IMMEDIATE VICINITY OF THE SITE. THE CONTRACTOR SHALL BE RESPONSIBLE FOR CLEAN-UP OF ANY MATERIALS DEPOSITED OUTSIDE THE WORK AREA.
39. CONTRACTOR SHALL CONFORM TO THE CITY OF ST. PETERSBURG NOISE CODE.
40. PIPE LENGTHS SHOWN ARE APPROXIMATE. LOCATIONS OF STRUCTURES SHALL GOVERN AND PIPE LENGTHS SHALL BE ADJUSTED ACCORDINGLY.
41. THE CONTRACTOR(S) PERFORMING TRENCH EXCAVATION ON THIS CONTRACT, IN EXCESS OF (5) FIVE FEET IN DEPTH, SHALL COMPLY WITH THE OCCUPATIONAL SAFETY AND HEALTH ADMINISTRATION'S (OSHA) TRENCH EXCAVATION SAFETY STANDARDS, 29 C.F.R., §1926.650, SUBPART P, INCLUDING ALL SUBSEQUENT REVISIONS OR UPDATES TO THE STANDARDS AS ADOPTED BY THE DEPARTMENT OF LABOR AND EMPLOYMENT SECURITY (DLES).
42. CONTRACTOR SHALL MAINTAIN ACCESS FOR LOCAL TRAFFIC. EXCAVATION SHALL BE LIMITED TO THE AMOUNT OF STORMWATER, POTABLE WATER, SANITARY SEWER PIPE OR ANY OTHER SUBSURFACE UTILITY TO BE INSTALLED WITHIN THE SAME WORKING DAY. TRENCHES SHALL BE BACKFILLED IN THE SAME DAY.
43. CONTRACTOR SHALL MAINTAIN AS-BUILT DRAWINGS IN GOOD ORDER AND LEGIBLE CONDITION TO BE CONTINUOUSLY MARKED UP AT THE JOB SITE. AS-BUILT DRAWINGS SHALL BE AVAILABLE FOR INSPECTION BY THE ENGINEER AT ALL TIMES DURING THE PROGRESS OF THE PROJECT. AS-BUILT DRAWINGS SHALL BE REVIEWED BY THE CITY INSPECTOR FOR ACCURACY AND COMPLIANCE PRIOR TO SUBMITTAL OF MONTHLY PAY REQUESTS.

TRAFFIC CONTROL NOTES

- 1. THE TRAFFIC IS TO BE MAINTAINED IN THE URBAN SECTION OF THE PROJECT IN ACCORDANCE WITH THE APPLICABLE SECTIONS OF THE FY 2020-21 FDOT STANDARD PLANS INDICES 102-600 THRU 102-670. ADVISORY SPEED PLATES AND REDUCED SPEED AHEAD SIGNS ARE TO BE USED IN CONJUNCTION WITH THE SIGNING SCHEMES SHOWN ON THE ABOVE INDEXES IN ACCORDANCE WITH THE INDEX NO. 102-600.
2. ALL EXISTING STREET SIGNS THAT ARE AFFECTED BY THE PROJECT SHALL BE RELOCATED AND MAINTAINED BY THE CONTRACTOR AT ALL TIMES FOR THE DURATION OF THE PROJECT.
3. THE CONTRACTOR SHALL NOTIFY THE FOLLOWING:

FIRE DEPARTMENT (727) 893-7526
SUN STAR EMERGENCY CENTER DISPATCH (727) 582-2073
ST. PETERSBURG POLICE DISPATCH CENTER (727) 893-7780
PSTA TRANSPORTATION DEPARTMENT (727) 530-9921
PINELLAS COUNTY (727) 464-3251

NO LESS THAN 48 HOURS IN ADVANCE OF ANTICIPATED DISRUPTION TO THE NORMAL FLOW OF TRAFFIC, INCLUDING LANE CLOSURES, DETOURS AND SIGNAL WORK.

- 4. THE CONTRACTOR SHALL BE RESPONSIBLE FOR DAMAGE TO CURB AND/OR GUTTER, SIDEWALK, ETC. DURING ALL CONSTRUCTION ACTIVITIES.
5. ALL TEMPORARY SIGNS, PAVEMENT MARKINGS, BARRICADES, WARNING LIGHTS, ETC. NECESSARY FOR THE MAINTENANCE OF TRAFFIC SHALL CONFORM TO THE MANUAL OF UNIFORM TRAFFIC CONTROL DEVICES (LATEST EDITION) AND THE FDOT STANDARD PLANS (2020-21)
6. THE CONTRACTOR SHALL KEEP THE ROADWAY OPEN AT NIGHT.

PEDESTRIAN NOTES

- 1. EXISTING SIDEWALK ADJACENT TO THE PROPOSED SIDEWALK SHALL BE SAW CUT. THE COST OF SAW CUTTING SHALL BE INCIDENTAL TO THE WORK BEING PERFORMED.
2. CONSTRUCTION STAGING SHALL NOT TAKE PLACE IN THE SIDEWALK NOR INTERFERE WITH SIDEWALK ACCESS OR SIDEWALK ACTIVITIES.
3. THE CONTRACTOR SHALL NOT STAGE OR STORE MATERIAL ON THE SIDEWALK.
4. NO CLOSURE OF THE SIDEWALK SHALL BE ALLOWED.
5. PEDESTRIAN TRAFFIC IS TO BE MAINTAINED AT ALL TIMES DURING THE CONSTRUCTION PROCESS. THE CONTRACTOR IS RESPONSIBLE FOR ENSURING THAT A SAFE, UNOBSTRUCTED ROUTE EXISTS FOR PEDESTRIANS, PER FDOT STANDARD INDEX NO. 102-660

NOTES FOR STORM STRUCTURES

- 1. ALL PIPE STUBS FROM STRUCTURES FOR FUTURE CONNECTIONS, SHALL BE INSTALLED WITH REMOVABLE WATERTIGHT PLUGS, PLACED FROM WITHIN THE STRUCTURE.
2. FOR APPLICABLE RING AND COVER, SEE STANDARD DETAIL-MANHOLE RING AND COVER CASTING.
3. STORM STRUCTURES SHALL NOT HAVE OUTSIDE DROP CONNECTIONS.
4. PROVIDE MINIMUM 8" SOLID WALL BETWEEN ALL OPENINGS FOR PIPES. SEAL BETWEEN PIPE AND STRUCTURE WITH NON SHRINK GROUT.
5. ALL BRICK SHALL BE CONCRETE OR CLAY BRICK AND SHALL HAVE A MINIMUM 3/4" CEMENT PLASTER COATING ON ALL SURFACES.
6. BENCH SHALL SLOPE @ 1:12 MINIMUM.
7. PRECAST AND CAST-IN-PLACE MANHOLES, CATCH BASINS, AND GRATE INLETS ARE DESIGNED FOR A MAXIMUM DEPTH OF 12 FEET, STRUCTURES IN EXCESS OF 12 FEET, AS MEASURED FROM THE FINISHED GRADE TO THE INSIDE OF THE BASE SLAB, SHALL REQUIRE VERIFICATION OF THE STRUCTURAL DESIGN AND SPECIFIC MODIFICATIONS TO THE REINFORCING REQUIREMENTS FOR THE DEPTH REQUIRED.
8. PRIOR TO PRECASTING STRUCTURES THE PRECASTER SHALL SUBMIT SITE SPECIFIC INDIVIDUAL SHOP DRAWINGS FOR APPROVAL. SHOP DRAWINGS SUBMITTED FOR NON-STANDARD STRUCTURES OR STRUCTURES THAT DEVIATE FROM THE STANDARD DETAILS MUST BE DESIGNED AND CERTIFIED BY A REGISTERED FLORIDA PROFESSIONAL ENGINEER.
9. PRECAST MANHOLES SHALL CONSIST OF A LIMITED NUMBER OF SECTIONS, AS APPROVED BY THE ENGINEER.
10. ALL PRECAST STRUCTURES SHALL HAVE AN INTEGRAL FLOOR AND BASE RISER SECTION.
11. SEE STANDARD DETAIL-PRECAST STRUCTURE JOINT ASSEMBLY AND STRUCTURE SEALING.
12. ALL EXPOSED EDGES TO HAVE 3/4" CHAMFER.
13. ALL REINFORCING STEEL SHALL HAVE A MINIMUM 2" CONCRETE COVER, UNLESS NOTED ELSEWHERE.
14. ADDITIONAL REINFORCEMENT IS REQUIRED IN ALL TYPE CATCH BASIN WALLS, GRATE INLETS, AND TYPE II, III, IV, AND TYPE V MANHOLE WALLS WITH OPENINGS FOR PIPE OR CULVERT. THE VERTICAL AND HORIZONTAL WALL REINFORCEMENT DISPLACED DUE TO OPENINGS SHALL BE REPLACED WITH ADDITIONAL REINFORCEMENT BARS ABOVE, BELOW, AND ON BOTH SIDES OF OPENING, EQUAL IN AREA TO THOSE DISPLACED. REPLACEMENT REINFORCEMENT SHALL BE PLACED WITH 3" CLEARANCE TO THE EDGES OF OPENINGS.

NOTES FOR SANITARY STRUCTURES

- 1. ALL MANHOLES SHALL BE BRICK, PRECAST CONCRETE OR FIBERGLASS REINFORCED POLYESTER (FRP), UNLESS OTHERWISE SHOWN OR APPROVED BY THE ENGINEER.
2. ALL PIPE STUBS FROM MANHOLES, FOR FUTURE CONNECTIONS, SHALL BE INSTALLED WITH REMOVABLE WATERTIGHT PLUGS, PLACED FROM WITHIN THE MANHOLE.
3. ALL TYPE I CONE SECTIONS SHALL BE CONCENTRIC WITH RING CASTING CENTERED IN STRUCTURE, UNLESS OTHERWISE SHOWN OR DIRECTED BY THE ENGINEER.
4. THE CONE SECTION OF TYPE I PRECAST MANHOLE SHALL BE PRECAST.
5. NO PIPE SHALL BE IN THE MANHOLE CONE SECTION.

Prepared By: DANIEL A. CARNLEY
P.E. NO.: 75529
WSP USA INC.
2202 N. WEST SHORE BLVD., SUITE 300
TAMPA, FL 33607

GENERAL NOTES



ENGINEERING & CAPITAL IMPROVEMENTS DEPARTMENT
CITY OF ST. PETERSBURG
CITY PROJECT MANAGER: EVAN BIRK, P.E.

1ST AVE S AND 2ND ST S
BIKEWAY IMPROVEMENTS
21063-112

DATE: 7/15/21
SCALE: NTS
DRAWING No. 11523-04

Table with columns: ITEM, BY, REMARKS, NAME, DATE, REVISIONS, BY, DATE. Contains revision tracking information.

**NOTES FOR SANITARY STRUCTURES (CONT.)**

- 6. ALL MANHOLES WITH SLAB TOP SHALL BE TYPE II, SEE STANDARD DETAIL-TYPE II MANHOLE TOP SLAB.
- 7. A DROP MANHOLE SHALL BE REQUIRED WHEN THE INVERT OF ANY INCOMING PIPE IS 24" OR MORE ABOVE THE INVERT OF THE MANHOLE. ALL DROP PIPE SHALL BE ON THE OUTSIDE OF THE MANHOLE.
- 8. PRIOR TO MANUFACTURING STRUCTURES THE MANUFACTURER SHALL SUBMIT SITE SPECIFIC INDIVIDUAL SHOP DRAWINGS FOR APPROVAL. SHOP DRAWINGS SUBMITTED FOR NONSTANDARD STRUCTURES OR STRUCTURES THAT DEVIATE FROM THE STANDARD DETAILS MUST BE DESIGNED AND CERTIFIED BY A REGISTERED FLORIDA PROFESSIONAL ENGINEER.
- 9. PRECAST MANHOLES SHALL CONSIST OF A MINIMUM NUMBER OF SECTIONS, AS APPROVED BY THE ENGINEER.
- 10. ALL PRECAST STRUCTURES SHALL HAVE AN INTEGRAL FLOOR AND BASE RISER SECTION, SEE STANDARD DETAIL-TYPE I AND II MANHOLE BASE AND WALL.
- 11. SEE STANDARD DETAIL-PRECAST STRUCTURE JOINT ASSEMBLY AND STRUCTURE SEALING.
- 12. ALL EXPOSED EDGES TO HAVE A 3/4" CHAMFER.
- 13. FOR THE APPLICABLE RING AND COVER, SEE STANDARD DETAIL-MANHOLE RING AND COVER CASTING.
- 14. PRECAST BASE SECTION SHALL BE INSTALLED ON A CONCRETE MAT WITHIN 2 HOURS OF PLACEMENT OF THE MAT.
- 15. ALL BRICK SHALL BE CLAY BRICK AND SHALL HAVE A MINIMUM 3/4" CEMENT PLASTER ON ALL SURFACES.
- 16. BENCH SHALL SLOPE @ 1:12 MINIMUM.
- 17. PRIOR TO MANUFACTURING OF FRP MANHOLE, MANUFACTURER SHALL SUBMIT SIGNED AND SEALED SHOP DRAWINGS FOR THE DESIGN OF INVERT AND BENCH AREA, PIPE CONNECTIONS, FABRICATION DETAILS AND INSTALLATION METHODS FOR APPROVAL.
- 18. ADDITIONAL REINFORCEMENT IS REQUIRED IN ALL TYPE II MANHOLE WALLS WITH OPENINGS FOR PIPES. THE VERTICAL AND HORIZONTAL WALL REINFORCEMENT DISPLACED DUE TO OPENINGS SHALL BE REPLACED WITH ADDITIONAL REINFORCEMENT BARS ABOVE, BELOW, AND ON BOTH SIDES OF OPENINGS, EQUAL IN AREA TO THOSE DISPLACED. REPLACEMENT REINFORCEMENT SHALL BE PLACED WITH 3" CLEARANCE TO THE EDGES OF OPENINGS.
- 19. FRP MANHOLE INVERT AND BENCH SHALL BE CONCRETE.
- 20. FRP STIFFENING RIBS ARE REQUIRED AT 10' DEPTH OR MORE.
- 21. THE CONTRACTOR SHALL NOTIFY THE RESPECTIVE PROPERTY OWNERS A MINIMUM OF 48 HOURS IN ADVANCE OF ANY AND ALL DISRUPTIONS TO SANITARY SEWER SERVICE. DISRUPTION IN SERVICE TO ANY RESIDENCE SHALL NOT EXCEED FOUR (4) HOURS, AND SHALL ONLY BE OUT OF SERVICE DURING WORKING HOURS. DISRUPTION IN SERVICE TO ANY BUSINESS SHALL BE COORDINATED WITH BUSINESS OWNER AND THE CITY.
- 22. CONTRACTOR TO PROVIDE PUMP-AROUND FOR ANY SANITARY SEWER MODIFICATION TO KEEP SANITARY SEWER IN OPERATION AT ALL TIMES.

**NOTES FOR PRESSURE PIPE**

- 14. ALL PRESSURE PIPE MATERIALS AND CONSTRUCTION METHODS SHALL CONFORM TO THE SPECIFICATIONS AND DETAILS AS SHOWN HEREIN, OR AS DIRECTED BY THE ENGINEER.
- 15. PIPE JOINT DEFLECTION SHALL NOT EXCEED 75% OF THE PIPE MANUFACTURE REQUIREMENTS.
- 16. THE CONTRACTOR SHALL ADJUST PIPELINE ALIGNMENTS HORIZONTALLY AND/OR VERTICALLY AS REQUIRED TO AVOID CONFLICTS WITH ACTUAL FIELD CONDITIONS AS UNCOVERED DURING CONSTRUCTION. FIELD ADJUSTMENTS SHALL BE COORDINATED WITH AND APPROVED BY THE ENGINEER.
- 17. PRESSURE PIPE CLEARANCES SHALL BE AS FOLLOWS:
  - A) POTABLE WATER MAINS IN PARALLEL INSTALLATIONS SHALL MAINTAIN A MINIMUM 6 FEET AND PREFERABLY 10 FEET OUTSIDE TO OUTSIDE HORIZONTAL CLEARANCE FROM ALL WASTEWATER GRAVITY MAINS, STORM DRAINS, AND WASTEWATER FORCE MAINS.
  - B) POTABLE WATER MAINS WHERE CROSSING SHALL MAINTAIN A MINIMUM OF 12 INCHES AND PREFERABLY 18 INCHES OUTSIDE TO OUTSIDE VERTICAL CLEARANCE ABOVE ALL WASTEWATER GRAVITY MAINS, STORM DRAINS, AND WASTEWATER FORCE MAINS.
  - C) POTABLE WATER MAINS SHALL MAINTAIN A MINIMUM OF 5 FOOT CENTER TO CENTER HORIZONTAL CLEARANCE OR 3 FOOT OUTSIDE TO OUTSIDE HORIZONTAL CLEARANCE, AND A MINIMUM OF 12 INCHES AND PREFERABLY 18 INCHES OUTSIDE TO OUTSIDE VERTICAL CLEARANCE FROM RECLAIMED WATER MAINS.
  - D) RECLAIMED WATER MAINS SHALL MAINTAIN A MINIMUM OF 5 FOOT CENTER TO CENTER HORIZONTAL CLEARANCE OR 3 FOOT OUTSIDE TO OUTSIDE HORIZONTAL CLEARANCE, AND A MINIMUM OF 12 INCHES AND PREFERABLY 18 INCHES OUTSIDE TO OUTSIDE VERTICAL CLEARANCE FROM WASTEWATER FORCE MAINS.
  - E) FULL LENGTH WASTEWATER FORCE MAIN PIPE SHALL BE CENTERED AT POTABLE WATER MAIN CROSSINGS SO THAT THE WATER MAIN JOINTS WILL BE AS FAR AS POSSIBLE FROM THE FORCE MAIN JOINTS.
- 5. THE CONTRACTOR SHALL COORDINATE WITH THE ENGINEER REGARDING SHUTTING DOWN WATER MAINS. PROPER AND ADEQUATE NOTIFICATION MUST BE MADE TO PROPERTY OWNERS, BUT IN NO CASE SHALL LESS THAN 24 HOURS WRITTEN NOTICE BE GIVEN.
- 6. THE OPENING AND/OR CLOSING OF EXISTING VALVES OR NEW VALVES INSTALLED IN PRESSURE PIPE SYSTEMS SHALL BE BY A CITY SANITARIAN AFTER COORDINATION WITH THE ENGINEER.
- 7. THE CONTRACTOR SHALL PROVIDE NECESSARY EQUIPMENT AND LABOR TO MAKE TAPS IN PRESSURE PIPE MAINS WHERE TAPPING SLEEVES AND VALVES ARE SHOWN ON THE PLANS.
- 8. ALL NEW DUCTILE IRON PRESSURE PIPE, FITTINGS, AND VALVE BODIES SHALL BE WRAPPED IN POLYETHYLENE IN ACCORDANCE WITH ANSI/AWWA C105.
- 9. THE CONTRACTOR SHALL BE RESPONSIBLE TO LOCATE AND PROTECT ALL EXISTING POTABLE AND RECLAIMED SERVICE LINES UNDER PAVEMENT OR ELSEWHERE IN THE CONSTRUCTION ZONE. REPLACE SERVICE LINES WHERE SHOWN OR DIRECTED BY THE ENGINEER. ALL RELOCATED SERVICE LINES SHALL BE RELOCATED SO THAT THE METER ASSEMBLY WILL NOT BE IN AN ALLEY, DRIVEWAY, OR OTHER VEHICULAR TRAVEL PATH.

- 10. ALL EXISTING POTABLE AND/OR RECLAIMED WATER SERVICE LINES SHALL BE TRANSFERRED TO THE NEW MAIN, UNLESS OTHERWISE DIRECTED BY THE ENGINEER.
- 11. MAINTAIN A MINIMUM COVER OF 36 INCHES UNDER ROADWAYS, ALLEYS, AND DRIVEWAYS. MAINTAIN A MINIMUM OF 30 INCHES OF COVER IN SODDED AND LANDSCAPED AREAS.
- 12. THRUST BLOCKING SHALL NOT BE USED, UNLESS ORDERED BY THE ENGINEER. RESTRAINED PIPE JOINTS SHALL BE USED. THE LENGTH OF RESTRAINED JOINTS SHALL BE AS SHOWN ON THE PLANS.
- 13. SANITARY SEWER FORCE MAINS SHALL NOT USE GREATER THAN 45° BENDS FOR OFFSETS OR REALIGNMENT OF THE FORCE MAIN. THE 45° BENDS SHALL HAVE A MINIMUM OF 5 FEET BETWEEN THEM, WHEN POSSIBLE.

**MANHOLE NOTES**

- 1. PRECAST MANHOLE SECTIONS SHALL BE MANUFACTURED IN ACCORDANCE WITH LATEST EDITIONS OF ASTM C-478 WITH 4000 P.S.I. TYPE II CEMENT.
- 2. PRECAST CONCRETE MANHOLE BASES SHALL HAVE A MINIMUM 28 DAY COMPRESSIVE STRENGTH OF 4000 P.S.I. AND SHALL UTILIZE TYPE II CEMENT.
- 3. CONCRETE PLACED IN MANHOLE INVERTS SHALL HAVE A MINIMUM 28 DAY COMPRESSIVE STRENGTH OF 4000 P.S.I. AND SHALL UTILIZE TYPE II CEMENT.
- 4. LIFT HOLES THROUGH PRECAST STRUCTURES ARE NOT PERMITTED.
- 5. ALL PIPE PENETRATIONS SHALL BE PRECAST OR CORE-DRILLED. THE PERIMETER OF PENETRATION SHALL NOT BE CLOSER THAN 12" TO A BARREL SECTION JOINT.
- 6. RUBBER BOOT TO BE USED AT ALL PIPE PENETRATIONS.
- 7. JOINT CONTACT SEALS SHALL BE PLACED AT ALL RISER JOINTS, 1/2" THICK WITH WIDTH AT LEAST 1/2 THE WALL THICKNESS.
- 8. THE INTERIOR OF THE ADJUSTMENT SECTION SHALL BE PLASTERED WITH 3/4" ACID RESISTANT MORTAR WHEN BRICK ADJUSTMENT RING IS USED. OTHER APPROVED EQUAL CONSTRUCTION MAY BE CONSIDERED.
- 9. MANHOLE COVER SHALL BE WATERTIGHT OR EQUIPPED WITH AN INFLOW PROTECTOR IN SODDED AREAS.
- 10. BOTTOM BARREL AND BASE OF MANHOLE TO BE MONOLITHICALLY OR INTEGRALLY CAST.
- 11. SERVICE LATERALS TO MANHOLES SHALL BE TREATED AS MAINS (CORE DRILLED FOR PENETRATION AND FLOW CHANNEL SHALL BE CONSTRUCTED).
- 12. PRECAST OR CORE-DRILLED PENETRATION DIAMETERS SHALL BE PER MANUFACTURER SPECIFICATIONS OR AS FOLLOWS:
  - a. 6" TO 8" FOR 4" DIAMETER PIPE
  - b. 10 TO 12" FOR 8" DIAMETER PIPE
  - c. 16" FOR 12" DIAMETER PIPE
- 13. MATERIALS OF CONSTRUCTION, PLACEMENT, AND COMPACTION REQUIREMENTS FOR BEDDING MATERIALS SHALL MEET CITY OF ST. PETERSBURG AND PINELLAS COUNTY SPECIFICATIONS.
- 14. FLOW CHANNELS SHALL BE CONSTRUCTED TO DIRECT INFLUENT INTO THE FLOW STREAM.
- 15. PROPERLY SHAPED SPILLWAYS SHALL BE CONSTRUCTED BETWEEN PIPES WITH DIFFERENT INVERT ELEVATIONS TO PROVIDE FOR SMOOTH FLOWS.

**UTILITIES NOTES**

- 1. PRIVATE UTILITIES THAT ARE IN CONFLICT WITH THE PROPOSED CONSTRUCTION HEREIN SHALL BE RELOCATED BY THE UTILITY OWNER. UNLESS OTHERWISE NOTED IN THE CONTRACT DOCUMENTS, CONTRACTOR SHALL COORDINATE THE SCHEDULE OF RELOCATION TO ENSURE IT IS PERFORMED IN A TIMELY MANNER.
- 2. CONTRACTOR SHALL FIELD VERIFY ALL CONNECTING POINTS (BEGINNING AND END), (LOCATION AND INVERTS) FOR UTILITIES PRIOR TO STARTING CONSTRUCTION AND SHALL IMMEDIATELY NOTIFY THE OWNER AND THE ENGINEER OF ANY DISCREPANCIES.
- 3. INFORMATION SHOWN ON THESE DRAWINGS AS TO THE LOCATION OF EXISTING UTILITIES HAS BEEN PREPARED FROM THE MOST RELIABLE DATA AVAILABLE TO THE ENGINEER. HOWEVER, IT IS NOT GUARANTEED. THE CONTRACTOR SHALL NOTIFY THE APPROPRIATE UTILITY COMPANY AND CALL THE STATE OF FLORIDA 811 NOTIFICATION CENTER AT 811, A MINIMUM OF 48 HOURS PRIOR TO EXCAVATION. CONTRACTOR SHALL BE RESPONSIBLE FOR DETERMINING THE LOCATION, CHARACTER AND DEPTH OF ANY EXISTING UTILITIES.
- 4. UNLESS WRITTEN APPROVAL FROM THE ENGINEER IS PROVIDED, THE LOWEST PIPE SHALL BE INSTALLED FIRST WHEN UTILITIES CROSS.
- 5. SANITARY SEWER GRAVITY LINES SHALL BE CONSTRUCTED OF PVC MATERIAL MEETING THE GENERAL SPECIFICATIONS OF ASTM D3034, SDR 26.
- 6. WASTEWATER GRAVITY SEWERS SHALL BE LAID AT LEAST 10 FEET HORIZONTALLY FROM ANY EXISTING OR PROPOSED POTABLE WATER MAIN.
- 7. A THREE FOOT HORIZONTAL SEPARATION SHALL BE MAINTAINED BETWEEN A WASTEWATER GRAVITY/FORCE MAIN AND ALL OTHER PIPELINE. THE DISTANCE SHALL BE MEASURED FACE TO FACE.
- 8. VERTICAL SEPARATION BETWEEN WASTEWATER SEWER MAINS CROSSING POTABLE WATER MAINS, RECLAIMED WATER MAINS, OR STORMWATER LINES SHALL BE MINIMUM VERTICAL DISTANCE OF 18 INCHES BETWEEN THE OUTSIDE SEPARATION OF THE LINES.
- 9. GRAVITY SEWER PIPE AND FITTINGS SHALL BE MADE OF PVC MATERIAL HAVING A CELL CLASSIFICATION OF 1254B, 12454 C OR 13354 B AS DEFINED IN ASTM D1784. SDR 26 PVC PIPE AND FITTINGS SHALL BE USED IN THE GRAVITY SEWER SYSTEM AND SHALL MEET REQUIREMENTS OF ASTM D3034.
- 10. MORTAR FOR PIPE, MANHOLE ADJUSTMENT RINGS AND BRICK JOINTS SHALL BE COMPOSED OF PORTLAND CEMENT AND SAND, CONFORMING TO ASTM C270
  - A) MORTAR SHALL CONSIST OF ONE PART PORTLAND CEMENT TYPE II CONFORMING TO ASTM C150, AND TWO (2) PARTS BY VOLUME OF WASHED SILICA MORTAR SAND CONFORMING TO ASTM C144

- B) LIME SHALL NOT BE USED.
- 11. NO PIPE SHALL BE LAID WHEN TRENCH CONDITIONS OR THE WEATHER IS UNSUITABLE FOR SUCH WORK.
- 12. MANHOLE BASE SECTIONS SHALL BE SET IN THE LEVELING COURSE OF CRUSHED STONE SUBBASE COMPACTED TO NOT LESS THAN 98% OF MAXIMUM DRY DENSITY AS DETERMINED BY THE MODIFIED PROCTOR TEST ASTM D1557.
- 13. THE TRENCH BACKFILL DENSITY FOR ALL STAGES SHALL BE COMPACTED TO 98% OF THE MAXIMUM DENSITY AS DETERMINED BY AASHTO T-180 (ASTM D1557 - MODIFIED PROCTOR) WITH A MINIMUM 2% TOLERANCE. THERE SHALL BE MINIMUM OF ONE TEST BETWEEN STRUCTURES AND NOT TO EXCEED 500 FEET HORIZONTALLY.
- 14. ELECTRONICALLY DETECTABLE TAPE SHALL BE INSTALLED IN TRENCHES ABOVE ALL PVC PIPING APPROXIMATELY 18 INCHES ABOVE THE PIPE.
- 15. CUTS FOR UTILITY REPLACEMENT OR RELOCATION SHALL BE RESTORED AS SOON AS THE REPLACEMENT OR RELOCATION IS COMPLETED.
- 16. PIPE LENGTHS SHOWN ARE APPROXIMATE. LOCATIONS OF STRUCTURES SHALL GOVERN AND PIPE LENGTHS SHALL BE ADJUSTED ACCORDINGLY.
- 17. IN THE CONTRACT DOCUMENTS, CONTRACTOR SHALL COORDINATE THE SCHEDULE OF RELOCATION TO ENSURE IT IS PERFORMED IN A TIMELY MANNER.
- 18. THE POLYETHYLENE TUBING FOR THE HOSE BIB SHALL BE SDR-9 200 PSI.
- 19. THREE INCH AND SMALLER HDPE TUBING SHALL BE PERFORMANCE PIPES "DRISCOPLEX", ENDOT "ENDOPURE", VANGUARD "BRUISER", OR APPROVED EQUAL.
- 20. THE CONTRACTOR SHALL ENSURE THAT ALL DRAINAGE STRUCTURES, PIPES, ETC. ARE CLEAN AND FUNCTIONING PROPERLY AT THE TIME OF ACCEPTANCE.

**SEDIMENTATION AND EROSION CONTROL NOTES**

- 1. ALL SOIL EROSION AND SEDIMENT CONTROL MEASURES SHALL BE INSTALLED PRIOR TO ANY MAJOR SOIL DISTURBANCE AND MAINTAINED THROUGH PROJECT COMPLETION.
- 2. CONSTRUCTION OPERATIONS SHALL BE CARRIED OUT IN SUCH A MANNER THAT EROSION AND WATER POLLUTION WILL BE MINIMIZED. ALL APPLICABLE FEDERAL, STATE AND LOCAL LAWS SHALL BE COMPLIED WITH AT ALL TIMES.
- 3. CONTRACTOR SHALL BE RESPONSIBLE FOR ALL EROSION AND WATER POLLUTION RESTORATION EFFORTS.
- 4. ALL EROSION AND SEDIMENT CONTROL MEASURES INDICATED ON THESE DRAWINGS ARE FOR START-UP AND REFERENCE. LOCATIONS MAY BE MODIFIED IN THE FIELD PER THE ENGINEER'S APPROVAL.
- 5. CONTRACTOR SHALL MAINTAIN SEDIMENT AND EROSION CONTROL MEASURES IN ACCORDANCE WITH THE CITY OF ST. PETERSBURG AND THE SOUTHWEST FLORIDA WATER MANAGEMENT DISTRICT (SWFWMD).
- 6. CONTRACTOR SHALL PROVIDE DUST CONTROL AND PROTECT ADJACENT PROPERTIES FROM THE ACCUMULATION OF SOIL, DEBRIS AND GARBAGE.
- 7. PRIOR TO START OF CONSTRUCTION, THE CONTRACTOR SHALL PREPARE A "STORMWATER POLLUTION PREVENTION PLAN" (SPPP) FOR THE OWNER'S APPROVAL AND SUBMIT THE SPPP ALONG WITH A NOTICE OF INTENT FDEP FORM 62-621.300(4)(B) TO THE NPDES STORMWATER NOTICES CENTER.

**GENERAL LANDSCAPING NOTES**

- 1. ALL PLANT MATERIALS TO BE FLORIDA #1 OR BETTER QUALITY, INSTALLED TO HIGHEST NURSERY STANDARDS.
- 2. MULCH TO BE RECYCLED WOOD MULCH, UNLESS OTHERWISE SPECIFIED. MULCH SHALL BE INSTALLED TO A MINIMUM OF 3" THICK IN ALL PLANTING AREAS.
- 3. SOD TO BE 95% WEED FREE: ARGENTINE BAHIA OR ST. AUGUSTINE "FLORATAM", AS SPECIFIED ON THE PLANS. SOD TO BE INSTALLED WITH TIGHT JOINTS, ROLLED AND FERTILIZED AT TIME OF INSTALLATION. ALL AREAS DISTURBED DURING PLANT REMOVAL AND/OR PLANTING WORK SHALL BE FILLED AND GRADED TO MATCH THE ADJACENT GRADE AND SODDED AS REQUIRED TO COVER ANY EXPOSED GROUND. SODDED AREAS SHALL BE INCLUDED IN THE ESTABLISHED WATERING PERIOD.
- 4. ALL DIMENSIONS TO BE FIELD CHECKED BY THE LANDSCAPE CONTRACTOR PRIOR TO CONSTRUCTION, WITH ANY DISCREPANCIES REPORTED IMMEDIATELY TO THE ENGINEER.
- 5. ALL MATERIALS MUST BE AS SPECIFIED ON THE LANDSCAPE PLAN. IF MATERIALS OR LABOR DO NOT ADHERE TO THE SPECIFICATIONS, THEY WILL BE REJECTED BY THE ENGINEER WITH PROPER INSTALLATION CARRIED OUT BY THE CONTRACTOR AT NO ADDITIONAL COST TO THE CITY.
- 6. NO SUBSTITUTIONS OR CHANGES OF ANY KIND WILL BE MADE AT THE TIME OF BIDDING, SO AS TO PROVIDE FOR EQUAL AND FAIR BID COMPARISONS.
- 7. ALL PERMITS NECESSARY ARE TO BE OBTAINED BY THE INSTALLING CONTRACTOR, UNLESS OTHERWISE SPECIFICALLY STATED IN THE SPECIFICATIONS.
- 8. NO CONTRACTOR IDENTIFICATION SIGNS SHALL BE PERMITTED ON THE PROJECT.
- 9. CAREFULLY REVIEW THE LANDSCAPE SPECIFICATIONS. THE INSTALLATION CONTRACTOR WILL BE HELD RESPONSIBLE FOR ALL ITEMS CONTAINED THEREIN.
- 10. ALL PLANT MATERIALS SHALL HAVE A ONE YEAR WARRANTY UNLESS OTHERWISE SPECIFIED IN THE CONTRACT DOCUMENTS.

**ENVIRONMENTAL NOTES**

- 1. THE CONTRACTOR SHALL COMPLY WITH THE LATEST REVISIONS TO THE PINELLAS COUNTY AND CITY OF ST. PETERSBURG LANDSCAPING AND TREE ORDINANCES AND THE SITE CLEARING AND ALTERATION ORDINANCES.
- 2. SPECIAL CARE IS TO BE TAKEN SO TREES TO BE PRESERVED REMAIN UNHARMED DURING CONSTRUCTION.

| ITEM | BY | REMARKS        | NAME | DATE | REVISIONS | BY | DATE |
|------|----|----------------|------|------|-----------|----|------|
|      |    | DESIGNED BY:   | KR   | 7/21 |           |    |      |
|      |    | DRAWN BY:      | RB   | 7/21 |           |    |      |
|      |    | CHECKED BY:    | CR   | 7/21 |           |    |      |
|      |    | SUPERVISED BY: | DC   | 7/21 |           |    |      |

|   |                          |   |   |   |  |
|---|--------------------------|---|---|---|--|
| Prepared By:<br><b>DANIEL A. CARNLEY</b><br>P.E. NO.: 75529<br>WSP USA INC.<br>2202 N. WEST SHORE BLVD., SUITE 300<br>TAMPA, FL 33607 | <b>GENERAL NOTES (2)</b> |  | <b>ENGINEERING &amp; CAPITAL IMPROVEMENTS DEPARTMENT</b><br>CITY OF ST. PETERSBURG<br><br>CITY PROJECT MANAGER:<br><b>EVAN BIRK, P.E.</b> | <b>1ST AVE S AND 2ND ST S</b><br><b>BIKEWAY IMPROVEMENTS</b><br>21063-112 | DATE: 7/15/21<br>SCALE: NTS<br>DRAWING No.<br>11523-05 |
|---|--------------------------|---|---|---|--|

**NOTE:**

REMOVAL OF EXISTING PAVEMENT MARKINGS SHALL BE COMPLETED BY WATER BLASTING UNLESS APPROVED BY THE ENGINEER.

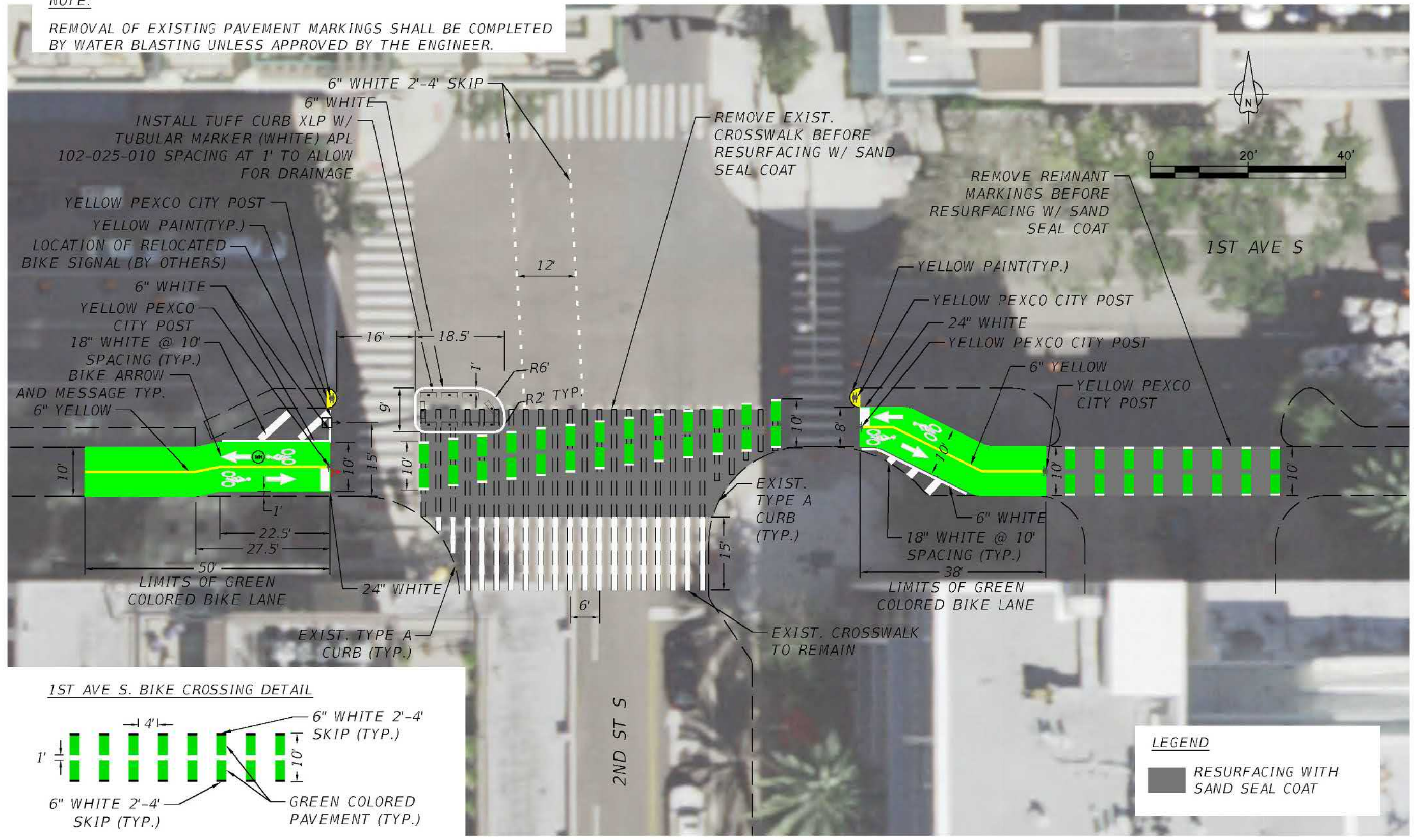

**1ST AVE S. BIKE CROSSING DETAIL**

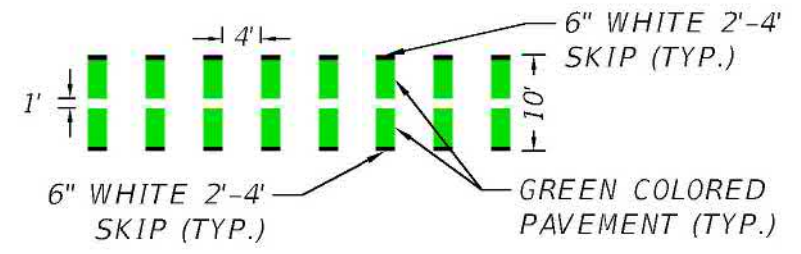

**LEGEND**

- RESURFACING WITH SAND SEAL COAT

| ITEM | BY | REMARKS        | NAME | DATE | REVISIONS | BY | DATE |
|------|----|----------------|------|------|-----------|----|------|
|      |    | DESIGNED BY:   | KR   | 7/21 |           |    |      |
|      |    | DRAWN BY:      | RB   | 7/21 |           |    |      |
|      |    | CHECKED BY:    | CR   | 7/21 |           |    |      |
|      |    | SUPERVISED BY: | DC   | 7/21 |           |    |      |

Prepared By:  
 DANIEL A. CARNLEY  
 P.E. NO.: 75529  
 WSP USA INC.  
 2202 N. WEST SHORE BLVD., SUITE 300  
 TAMPA, FL 33607

SITE PLAN



ENGINEERING & CAPITAL  
 IMPROVEMENTS DEPARTMENT  
 CITY OF ST. PETERSBURG

CITY PROJECT MANAGER:  
 EVAN BIRK, P.E.

1ST AVE S AND 2ND ST S  
 BIKEWAY IMPROVEMENTS  
 21063-112

|                         |
|-------------------------|
| DATE: 7/15/21           |
| SCALE: 1:20             |
| DRAWING No.<br>11523-06 |

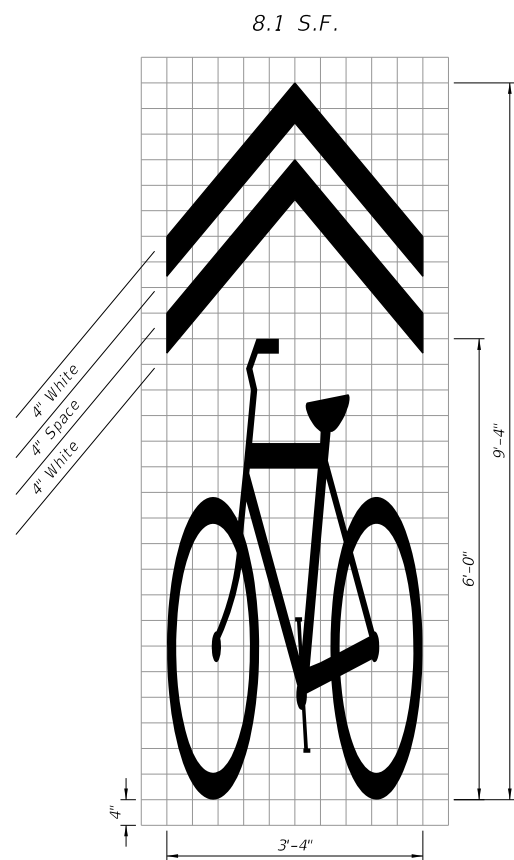

SHARED LANE MARKING (SLM)

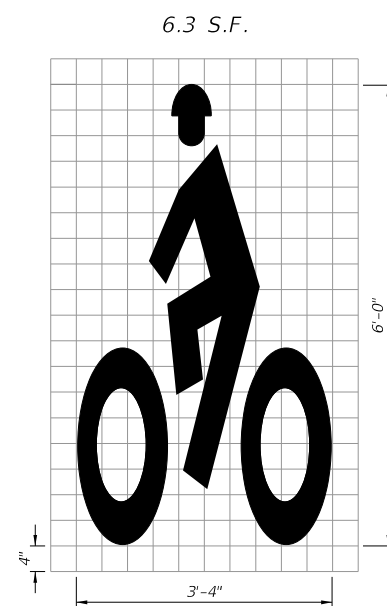

HELMETED BICYCLIST SYMBOL

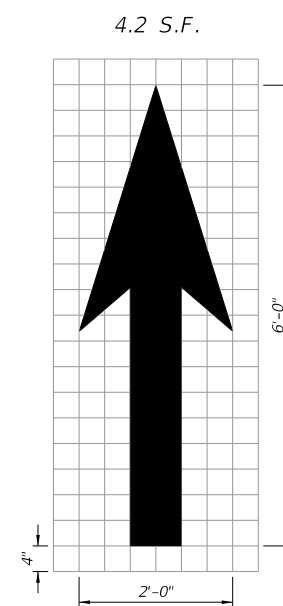

BIKE LANE ARROW

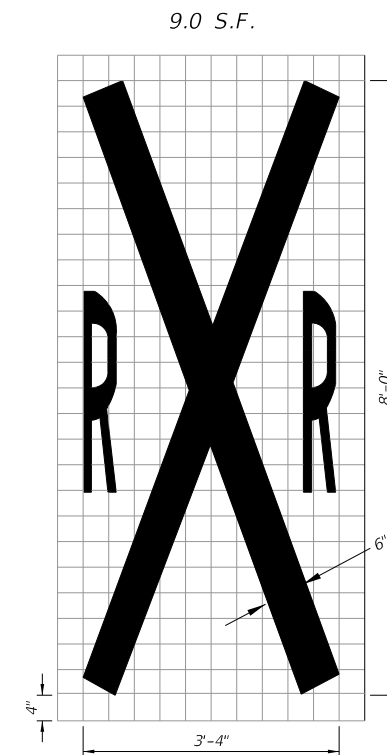

RAILROAD CROSSING

NOTES:

1. All bicycle markings and pavement messages shall be White.
2. All bicycle markings shall be preformed thermoplastic.
3. All grids are 4" x 4".

STANDARD PAVEMENT MARKING MESSAGE LAYOUTS

1/29/2021 12:08:51 PM

|                           |          |              |   |                  |                  |                 |
|---------------------------|----------|--------------|---|------------------|------------------|-----------------|
| LAST REVISION<br>11/01/17 | REVISION | DESCRIPTION: | <br>FY 2021-22<br>STANDARD PLANS | BICYCLE MARKINGS | INDEX<br>711-002 | SHEET<br>1 of 2 |
|---------------------------|----------|--------------|---|------------------|------------------|-----------------|

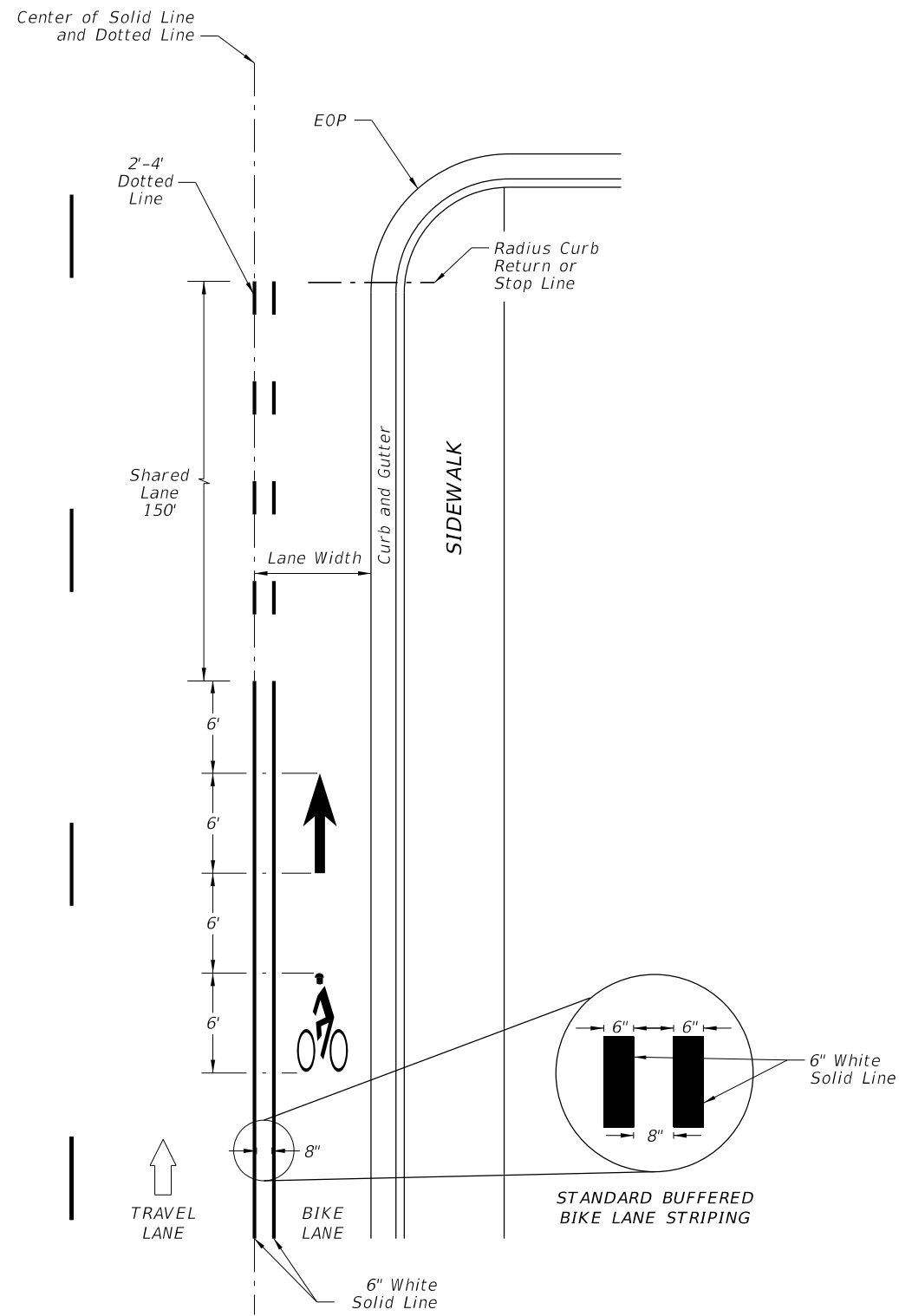

APPROACH TO INTERSECTIONS DETAILS

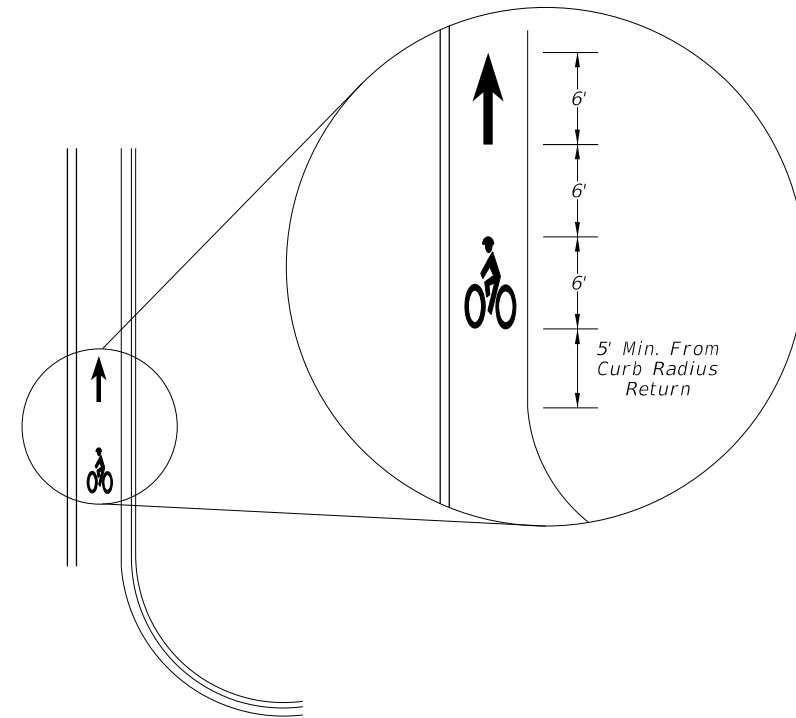

FAR SIDE OF INTERSECTION DETAIL

**BUFFERED BIKE LANES**

10/12/2020 9:10:53 AM

|                           |                       |  |                  |                  |                 |
|---------------------------|-----------------------|--|------------------|------------------|-----------------|
| LAST REVISION<br>11/01/17 | REVISION DESCRIPTION: |  FY 2021-22<br>STANDARD PLANS | BICYCLE MARKINGS | INDEX<br>711-002 | SHEET<br>2 of 2 |
|---------------------------|-----------------------|--|------------------|------------------|-----------------|



**COVERING EXISTING PAVEMENT MARKINGS WITH SAND SEAL COAT.  
(REV 2-11-04)**

**SECTION 311  
COVERING EXISTING PAVEMENT MARKINGS  
WITH SAND SEAL COAT**

**311-1 Description.**

Remove existing pavement markings by method approved by the Engineer and cover with a sand seal coat composed of an application of bituminous material followed by the application of a sand cover material across the full width of the roadway.

**311-2 Materials.**

**311-2.1 Bituminous Material:** Meet the following requirements:

Asphalt Binder, PG 67-22..... 916-1

Emulsified Asphalt, Grade RS-1..... 916-4

Note: During the months of November through April, use emulsified asphalt. During the remaining months of the year, use either asphalt binder (PG 67-22) or emulsified asphalt, or as specified in the Contract.

**311-2.2 Cover Material:** Use silica sand meeting the requirements of 902-2.

**311-3 Proportioning.**

Use the following approximate proportions for the sand seal coat:

Bituminous Material ..... 0.11 - 0.13 gal/yd<sup>2</sup>

Cover Material ..... 0.076 - 0.094 ft<sup>3</sup>/yd<sup>2</sup>

The Engineer will designate the actual application rate for each material based on a uniform distribution of the material that is adequate to cover the existing pavement markings.

**311-4 Equipment.**

**311-4.1 Power Broom:** Provide a power broom for cleaning the existing pavement capable of removing all loose material from the surface.

**311-4.2 Spreading Equipment:** Provide a self-propelled aggregate spreader that can be adjusted to accurately apply the cover material at the specified rate and that spreads the material uniformly.

**311-4.3 Traffic Rollers:** Provide a self-propelled, pneumatic-tired traffic type roller meeting the requirements of 330-5.3.2.

**311-4.4 Pressure Distributor:** Use a pressure distributor to apply the bituminous material which is capable of maintaining the material at the specified temperature and applying it in a uniform manner.

**311-5 Weather Limitations.**

Do not apply bituminous material when the weather conditions or the surface conditions at the location where the application is to be made are such that it will prevent an adequate bond of the sand seal coat materials to the pavement.

**311-6 Construction Methods.****311-6.1 Application of Bituminous Material:**

**311-6.1.1 Distributor Pressure:** After cleaning the surface to be treated to the satisfaction of the Engineer, uniformly apply the bituminous material over the surface by means of a pressure distributor. Use a distributor that maintains a pressure of at least 20 psi, but not more than 75 psi, or as specified by the Manufacturer.

**311-6.1.2 Application Temperatures:** For asphalt binder, maintain an application temperature between 300 and 350°F. For emulsified asphalt, maintain an application temperature between 100 and 170°F.

**311-6.1.3 Uniformity of Distribution:** Take special precautions to obtain an even and uniform distribution of bituminous material, and adjust and operate the distributor so as to maintain a uniform, even distribution of the type of material being applied. Immediately remove excessive deposits of bituminous material upon the road surface which are caused by stopping or starting the distributor, by leakage, or otherwise.

**311-6.1.4 Limitations to Application:** Ensure that the area to be covered by any one application of bituminous material is not greater than the aggregate can cover without interruption due to limitations of hauling and spreading equipment or to any other cause.

**311-6.2 Application of Cover Material:** Apply sand uniformly at the rate designated by the Engineer. If the Engineer considers it necessary for the proper distribution of the material, lightly drag the sand with a drag broom. Roll the entire area of the sand with at least two full coverages of a traffic roller.

**311-7 Method of Measurement.**

Payment of Sand Seal Coating (Bituminous and Sand) will be by the square yard used to cover the existing striping.

**311-8 Basis of Payment.**

Prices and payments will be full compensation for all work and materials specified in this Section.

Payment will be made under:

Item No. 904-311- Sand Seal Coating- Square Yard.

**CHANNELIZING CURB**  
**(REV 11-2-20)**

The following new Section is added after Section 701:

**SECTION 703**  
**CHANNELIZING CURB**

**703-1 Description.**

Furnish and install channelizing curb at the locations for hardened centerlines as called for in the Plans.

**703-2 Materials.**

Products must be manufactured from rubber.

Manufacturers seeking evaluation of Channelizing Curb products for inclusion on the IPL shall submit an application in accordance with Section 6 and include the following documentation.

| Table 703-1 Manufacturer's Requirements for IPL Inclusion |   |
|---|---|
| Documentation   | Requirement   |
| Product Photo   | Displays the significant features of the product.   |
| Technical Data Sheet                                      | Uniquely identifies the product and includes product specifications, storage instructions, and recommended installation materials and equipment as applicable.                  |
| Safety Data Sheet for Adhesive (if required)              | SDS meeting OSHA requirements for product and manufacturer recommended installation materials as applicable.  |
| Installation Instructions                                 | Include mounting surface preparations, and touch-up and repair procedures. Separate installation instructions are required for different substrates.                            |
| Product Sample  | Upon request from the Department, submit a sample of the material or hardware. If the product is a system comprised of multiple parts, a sample of each part must be submitted. |

**703-3 Dimensions.**

Provide channelizing curb with lengths as specified in the plans with allowance for additional length for variations in end-cap lengths. The height must range from 2 inches to 3 inches. The width must range from 12 inches to 16 inches.

**703-3 Color.**

Use the same color as the pavement marking being supplemented. Color must be homogenous throughout the product. Alternating black and colored segments are not acceptable.

**703-4 Product Acceptance on the Project.**

Use channelizing curb products listed on the Department's Innovative Products List (IPL).

**703-5 Installation Requirements.**

Install channelizing curb in accordance with the manufacturer's installation instructions posted on the IPL. If other products that are not currently listed on the IPL are desired, contact the monitor so they can be placed on the IPL.

**703-6 Method of Measurement.**

The quantity to be paid will be the number of channelizing curb units (not segments) furnished, installed, and accepted. The standard length of each unit is 6 feet not including end caps.

**703-7 Basis of Payment.**

Prices and payments will be full compensation for work specified in this Section, including the cost of labor, materials, and incidental items required to complete the work.

Payment will be made under:

Item No. 921-703- Channelizing Curb - each.

Do Not Use Without  
CO Specs Authorization

**OBJECT MARKERS AND DELINEATORS**  
**(REV 10-22-20)**

SECTION 705 is deleted and the following substituted:

**SECTION 705**  
**OBJECT MARKERS AND DELINEATORS**

**705-1 Description.**

Furnish and install object markers to mark obstructions within or adjacent to the roadway of the types and at the locations called for in the Standard Plans or in the Plans.

Furnish and install delineators along the side of the roadway to indicate the alignment of the roadway as indicated in the Standard Plans or in the Plans.

Furnish and install linear barrier delineators at locations called for on the Plans. Use the same color as the edge line pavement marking being emphasized.

**705-2 Materials.**

**705-2.1 General:** Meet the following requirements:

|                                     |             |
|-------------------------------------|-------------|
| Object Markers and Delineators..... | Section 993 |
| Retroreflective and Nonreflective   |             |
| Sign Sheeting.....                  | Section 994 |

**705-2.2 Product Acceptance on the Project:** Ensure that delineators and delineator posts are listed on the Department's Approved Product List (APL). For linear barrier delineators, submit to the Engineer, certification from the manufacturer that the requirements of Section 993 are met.

**705-3 Installation Requirements.**

Install delineators and object markers in accordance with the MUTCD, Standard Plans and Plans.

Place barrier delineators at a spacing of 25 feet for the first 100 feet of barrier and at 100 feet spacing thereafter. Orient barrier delineators as detailed in the Standard Plans or APL drawings.

Install linear barrier delineators in accordance with the Plans and Manufacturer's recommendations. Prepare their surfaces in accordance with manufacturer's recommendations to ensure proper bonding or connection. For guardrail applications, center between post bolt slots. For concrete barrier and traffic railing applications, use a gap of 3 feet plus or minus 2 inches.

**705-4 Method of Measurement.**

The quantity to be paid will be the number of delineators or object markers furnished, installed and accepted, with the exception of barrier delineators on new barriers, which are included in the cost of the barrier.

The linear foot length of linear barrier delineator will be the Plan Quantity length from the beginning of the linear barrier delineators to the end of the linear barrier delineators and will include the length of gaps.

**705-5 Basis of Payment.**

Prices and payments will be full compensation for work specified in this Section, including the cost of labor, materials, and incidental items required to complete the work.

Payment will be made under:

- |                   |  |
|-------------------|--|
| Item No. 705- 10  | Object Marker - each.                    |
| Item No. 705- 11  | Delineator - each.                       |
| Item No. 920-705- | Linear Barrier Delineator – linear feet. |

Do Not Use Without  
CO Specs Authorization

**GREEN-COLORED PAVEMENT MARKINGS.**  
**(REV 6-10-21)**

The following new Section is added after Section 713:

**SECTION 714**  
**GREEN-COLORED PAVEMENT MARKINGS**

**714-1 Description.**

Apply new green-colored pavement markings in accordance with the Contract Documents.

**714-2 Materials.**

Use only materials listed on the Innovative Product List (IPL) and meeting the following requirements:

Green-Colored Pavement Marking Materials..... Section 976

**714-3 Equipment.**

Use equipment in accordance with the manufacturer's installation instructions.

**714-4 Application.**

**714-4.1 General:** Remove existing pavement markings using a method approved by the Engineer such that pavement surface scars or traces of the removed pavement markings will not conflict with new pavement markings. Do not use paint to blackout, hide, or disguise existing pavement markings.

For installation on new asphalt roadways, apply pavement markings a minimum of 14 days after placement of the final asphalt surface course.

Before applying pavement markings, remove any material that would adversely affect the bond of the pavement markings by a method approved by the Engineer. Follow the manufacturer's recommendations for surface preparation.

For each green-colored pavement marking location, produce and provide a video record of the pavement before and after installations. Video records with timestamp will be provided to the Department within one week after installation. Provide video files via digital media (DVD, flash drive, or other) or by online digital distribution with a minimum standard resolution of 720 x 480 and at a speed not greater than 6 feet per second. The video image shall be clear, focused, and relatively free from roll, static, or other image distortion qualities that would prevent the reviewer from evaluating the condition of the roadway surface.

**714-4.2 Preformed Thermoplastic:**

Apply a primer, sealer, or surface preparation adhesive as recommended by the manufacturer's recommendations prior to installation.

Apply markings to dry surfaces only and when ambient air temperature is at least 32°F. Prior to installation, follow the manufacturer's recommendations for pre-heating. Apply 0.125 inch or 125 mils of preformed thermoplastic material. Apply skid resistant material in accordance with the manufacturer's instructions.

**714-4.3 Two Reactive Component Pavement Markings:** Install two reactive component pavement markings in accordance with manufacturer's recommendations.

Install two reactive component pavement markings in areas subject to vehicular traffic to a thickness meeting manufacturer recommended thickness requirements.

**714-5 Contractor's Responsibility for Notification.**

Notify the Engineer prior to the placement of the materials. At the time of notification, submit a certification to the Engineer with the Product name and the batch or Lot numbers of the preformed thermoplastic or two component reactive pavement markings to be used.

**714-6 Protection of Newly Applied Pavement Markings.**

Do not allow traffic onto or permit vehicles to cross newly applied pavement markings until they are sufficiently dry. Remove and replace any portion of the pavement markings damaged by passing traffic or from any other cause, at no additional cost to the Department.

**714-7 Method of Measurement.**

The quantity to be paid for will be the plan quantity area, in square feet, of green-colored pavement markings acceptably applied, subject to 9-1.3.2.

**714-8 Basis of Payment.**

Prices and payments will be full compensation for all work specified in this Section, including, all cleaning and preparing of surfaces, furnishing of all materials, application, curing and protection of all items, protection of traffic, furnishing of all tools, machines and equipment, and all incidentals necessary to complete the work. Final payment will be withheld until all deficiencies are corrected.

Payment will be made under:

Item No. 920- 714- Green-Colored Pavement Markings – per square foot.



**GREEN-COLORED PAVEMENT MARKING MATERIALS.  
(REV 7-22-20)**

The following new Section is added after Section 975:

**SECTION 976  
GREEN-COLORED  
PAVEMENT MARKING MATERIALS**

**976-1 General Requirements.**

**976-1.1 Innovative Products List Requirements:** To qualify for the Innovative Products List (IPL), manufacturers will submit products to the Department for evaluation. The Department will test all green-colored pavement marking materials in accordance with FM 5-622. Manufacturers must identify the materials for all components of the green-colored pavement marking materials system.

**976-1.2 Packaging and Labeling:** The name and address of the manufacturer shall be shown on the label. The label must also show the color, date of manufacture, and lot number. The label shall warn the user of any special handling or precautions of the material, as recommended by the manufacturer. Any packaging and labeling not so marked will not be accepted.

**976-1.2.1 Two Reactive Components:** The two reactive component material containers shall be clearly marked with the volume of materials in units of gallons and the product name.

**976-1.2.2 Preformed Thermoplastic:** The thermoplastic material shall be packaged in suitable biodegradable or thermo-degradable containers which will not adhere to the product during shipment and storage. Clearly mark each container with the thickness of the preformed material in units of inches.

**976-1.3 Storage:** All materials must have a shelf life in accordance with the manufacturer's recommendations.

**976-1.4 Initial Performance Requirements:** The green-colored pavement marking materials shall meet the following initial performance requirements and will be tested in accordance with FMS 622 – Part A. Manufacturers shall submit two samples of the product system (binder and aggregate) to the State Materials Office on a 19-3/4 inches by 15-3/4 inches steel plate, that is a minimum of 1/16 inch thick.

**976-1.4.1 Friction Resistance:** The surface of the pavement markings shall provide a Dynamic Friction Test (DFT40) value of 50 or greater.

**976-1.4.2 Color:** The initial daytime luminance factor (Y) must be greater than or equal to 15. The initial daytime chromaticity (x, y) must fall within the box created by the following coordinates:

| Table 976-1   |       |       |       |       |
|---|-------|-------|-------|-------|
| Initial Daytime Chromaticity Coordinates for Green-Colored Pavement Marking Materials (Corner Points) |       |       |       |       |
|   | 1     | 2     | 3     | 4     |
| x   | 0.230 | 0.266 | 0.367 | 0.444 |
| y   | 0.754 | 0.460 | 0.480 | 0.583 |

**976-1.5 In-Service Performance Requirements:** Green-colored pavement marking materials shall maintain the following performance requirements at the end of the three-year period and will be tested in accordance with FM5-622 – Part B.

**976-1.5.1 Friction Resistance:** The surface of the pavement markings shall provide a Dynamic Friction Test (DFT40) value of 40 or greater.

**976-1.5.2 Wear:** Wearing of the material coating shall not expose more than 15% of the underlying surface area.

**976-1.5.3 Pavement Distress:** Pavement distress occurring after installation of green-colored pavement marking materials may result in removal from the IPL, and require the manufacturer to mill, resurface, replace, and install with a product on the IPL at no additional cost to the Department.

**976-1.6 Additional Requirements:** Pavement marking materials shall be characterized as non-hazardous as defined by Resource Conservation and Recovery Act (RCRA) 40 CFR 261. Provide supporting independent analytical data or product material safety data sheets (SDS) identifying any components listed in Table 976-1 of 40 CFR 261.24. Additionally, glass elements shall contain no more than 200 ppm by weight of lead or arsenic when tested in accordance with the Environmental Protection Agency (EPA) Testing Methods 3052, 6010B, and 6010C.

Submit installation instructions including the number of coats and the thickness of each coat, if applicable.

## **976-2 Composition.**

The product installed shall consist of high-quality materials, producing an adherent, weather-resistant, friction-resistant, wear-resistant surface, and shall be uniformly distributed throughout the cross-sectional area. Color shall be integral and consistent throughout the installation.

## **976-3 Manufacturer's Warranty.**

The manufacturer must provide a three-year manufacturer's warranty to the Department. At a minimum the warranty must include that the product is warranted by the manufacturer for this specification intended use, meets stated minimum requirements and conditions of this specification, and is unchanged from materials, formulation, installation methods, and performance and test values as submitted to the Department. The manufacturer's warranty shall be satisfactory to the Department and requires the manufacturer to provide and maintain a listing of projects/locations where the product has been installed

**OBJECT MARKERS AND DELINEATORS**  
**(REV 10-22-20)**

SECTION 993 is deleted and the following substituted:

**SECTION 993**  
**OBJECT MARKERS AND DELINEATORS**

**993-1 Object Markers.**

**993-1.1 General:** Object markers shall meet the general requirements outlined in the Manual of Uniform Traffic Control Devices (MUTCD). For uniformity, all Type 1 markers shall be OM1-3 style markers, all Type 2 markers shall be OM2-2V style markers, and all Type 4 (end of road) markers shall be OM4-3 style markers.

**993-1.2 Retroreflective Sheeting:**

**993-1.2.1 Retroreflective Sheeting:** The retroreflective sheeting for object markers shall meet the requirements of Section 994, sheeting Types IV, V or XI. The retroreflective area shall be in accordance with the MUTCD. The retroreflective sheeting shall be permanently adhered to 0.040-inch sheet aluminum for Type 2 markers and 0.080-inch sheet aluminum for Type 1, 3 and end of the road markers. Aluminum shall be of 6061-T6 (ASTM B209) prepared in accordance with recommendations of the sheeting manufacturer.

**993-1.2.2 Assembly:** Type 2 and 3 markers shall be mounted directly to the post by two holes on the face of the marker. The mounting holes shall be 1/4-inch square holes to receive 1/4-inch carriage bolts, or other 1/4-inch bolts and shall be spaced to fit holes on the post spaced at 1-inch centers.

**993-1.3 Posts:** The marker posts shall be of steel or aluminum as shown in the Standard Plans or the Plans. Steel posts shall be 3 lb/ft. flanged U-Channel. The U-channel posts shall meet the mechanical requirements of ASTM A499, Grade 60. Provide U-channel posts that have been galvanized after fabrication in accordance with ASTM A123 and have a smooth uniform finish free from defects affecting strength, durability, and appearance. For each U-channel, punch or drill 3/8-inch diameter holes on 1-inch centers through the center of the post, starting approximately 1 inch from the top and extending the full length of the post. Punching or drilling operations shall be completed prior to galvanization. The weight per foot of a manufacturer's U-channel size shall not vary more than plus or minus 3.5% of its specified weight per foot. Machine-straighten the U-channel to a tolerance of 0.4% of the length. U-channel posts shall be listed on the APL. Round aluminum posts shall meet the requirements of Standard Plans, Index 700-010.

Use attachment hardware (nuts, bolts, clamps, brackets, braces, etc.) of aluminum or galvanized steel.

**993-2 Delineators.**

**993-2.1 General:** Delineators shall be classified into the following types: flexible post delineators, nonflexible post delineators, barrier delineators, and linear barrier delineators.

**993-2.2 Flexible Post Delineators:**

**993-2.2.1 Dimensions:** The post shall have a minimum width of 3 inches facing traffic and of such length to generally provide a height of 48 inches above the pavement surface.

**993-2.2.2 Color:** The post shall be opaque white. The yellowness index shall not exceed 12 when tested in accordance with ASTM E313. The daytime 45 degrees, 0 degrees luminance factor, Cap Y, shall be a minimum of 70, tested in accordance with ASTM E1347 or ASTM E1164.

**993- 2.2.3 Retroreflective Sheeting:** The reflective sheeting shall be Types IV, V, or XI and meet the requirements of Section 994. The reflective sheeting shall have a minimum width of 3 inches and have a minimum area of 30 square inches.

**993-2.2.4 Impact Performance:** Six of the eight posts shall be capable of returning to a vertical position plus or minus 10 degrees with no delaminating. No post shall split, crack, break, or separate from base. Posts shall be tested and evaluated according to the National Testing Product Evaluation Program (NTPEP) Evaluation of Temporary Traffic Control Devices: Flexible Delineators, for the following categories:

**993-2.2.4.1 Pavement/Surface mounted:** Use the Metropolitan Delineator Applications category for Hot Weather with a minimum of 10 impacts (default testing procedure uses a maximum of 200 impacts).

**993-2.2.4.2 Ground mounted:** Use the Ground Mount Side of Roadway Applications category for Hot Weather (default testing procedure uses a maximum of 10 impacts).

**993-2.3 Nonflexible Post Delineators:**

**993-2.3.1 Posts:** The posts shall meet the requirements of 993-1.4, except the steel delineator post shall be 1.1 lb/ft.

**993-2.3.2 Retroreflective Sheeting:** The retroreflective sheeting shall be Types IV, V or XI sheeting and meet the requirements of Section 994. The reflective sheeting shall have a minimum width of 4 inches and have a minimum area of 32 square inches. The retroreflective sheeting shall be permanently adhered to 0.040-inch sheet aluminum.

**993-2.4 Barrier Delineators:**

**993-2.4.1 General:** Barrier delineators shall consist of retroreflective sheeting permanently adhered to 0.090-inch minimum thick body. The body shall have a flexible hinge which allows the reflector to fold down and spring back to an upright position after impact. Barrier delineators for guardrail shall be designed for mounting to the web of steel posts or designed for mounting to the top of wood posts. Barrier delineators for concrete barrier, traffic railings, and vehicular longitudinal channelizing devices (LCDs) shall be designed for mounting to the top of each device.

**993-2.4.2 Retroreflective Sheeting:** The sheeting for barrier delineators shall be Type IV or XI meeting the requirements of Section 994. The sheeting shall be yellow or white, depending on the locations of use for each. The dimensions of the retroreflective sheeting shall be 3 inches wide by 4 inches high. The sheeting shall be installed by the delineator manufacturer.

**993-2.5 Linear Barrier Delineators:**

**993-2.5.1 General:** Linear barrier delineators shall consist of retroreflective sheeting permanently adhered to a substrate capable of being attached to the face of the barrier. Linear barrier delineators for guardrail shall be designed for mounting between post bolt slots in the trough of the W-Beam panel along the centerline of the post bolt slots. Linear barrier delineators for concrete barrier and concrete traffic railings shall be designed for mounting to the traffic face at a height of 2 feet from the gutter line.

**993-2.5.2 Retroreflective Sheeting:** The sheeting for linear barrier delineators shall be Type IV or XI meeting the requirements of Section 994. The sheeting shall be yellow or

white. Linear barrier delineators for guardrail shall have retroreflective sheeting with dimensions of 1 1/2 inches by a length ranging from 31 inches to 36 inches. Linear barrier delineators for concrete barrier and concrete traffic railings shall have retroreflective sheeting with dimensions of 6 inches by a length ranging for 31 inches to 36 inches. The sheeting shall be installed on the substrate by the linear barrier delineator manufacturer.

**993-3 Product Acceptance on the Project.**

Acceptance will be made in accordance with the requirements of Section 705. Manufacturers seeking evaluation of their product must submit an application in accordance with Section 6.

Do Not Use Without  
CO Specs Authorization

# 2.375" (60mm) Tuff Post

## Hi Performance Channelizer Post

Tuff Posts are available in 48" length with an OD of 2.375" (60mm) . Available in orange with white sheeting.

### TUBULAR MARKER STYLE

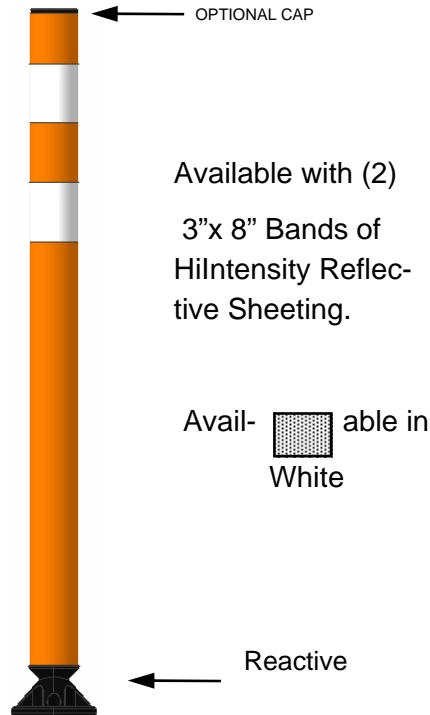

## To be Used With Tuff Curb XLP

### SPECIFICATIONS

- Post is constructed of flexible plastic that is resistant to: ultraviolet light, ozone, and hydrocarbons.
- Unit has a reactive spring assembly set to 110-145 lb. compression with stainless steel cable.
- Meets MUTCD Specifications

### RECOMMENDED USES

- Mountable to Tuff Curb® systems.

**IMPACT**recovery  
**SYSTEMS**

"Performance for a Safer Tomorrow"

4955 Stout Dr. San Antonio, TX 78219

210.736.4477, 800.736.5256, fax: 210.734.6448

# Opposing Traffic Lane Divider

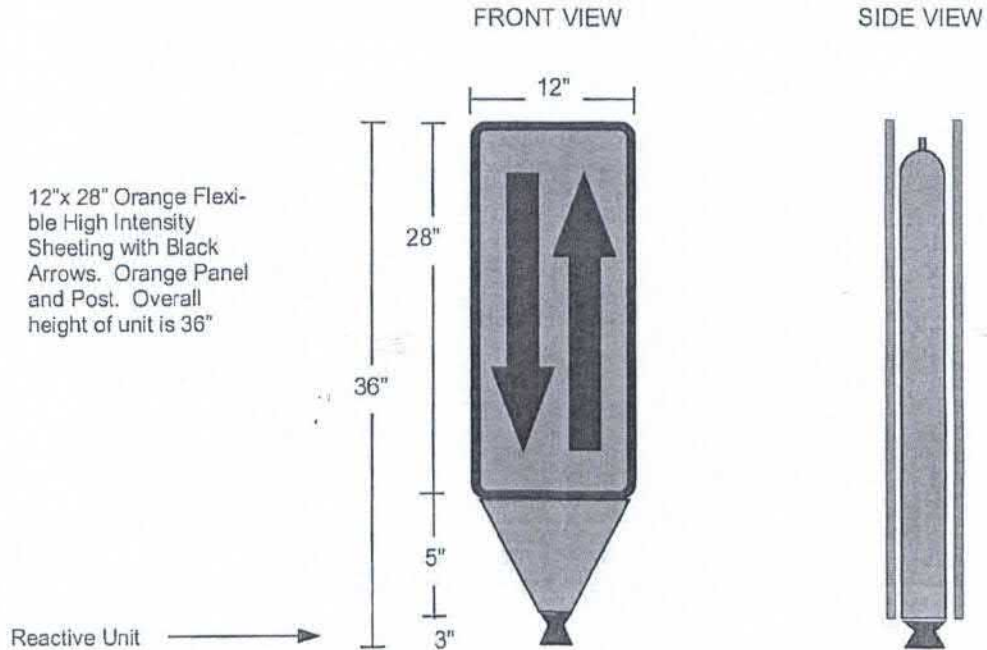

For Use With Tuff Curb XLP

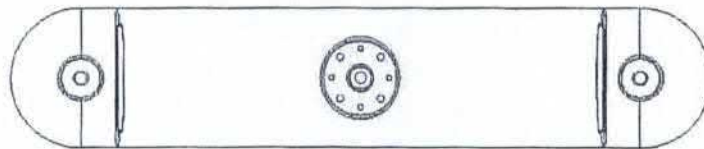

## SPECIFICATIONS

- Post and panel is constructed of flexible polyethylene plastic that is resistant to: ultraviolet light, ozone, and hydrocarbons.
- Unit has a reactive spring assembly tested to 200 lb tension with stainless steel cable.
- Meets MUTCD Specifications

## RECOMMENDED USES

- Ideal for use in providing positive lane division in work zones.

**IMPACT**recovery  
**SYSTEMS**

Performance for a Water Tomorrow™

4955 Stout Dr. San Antonio, TX 78219  
210.736.4477, 800.736.5256, fax: 210.734.6448  
[www.impactrecovery.com](http://www.impactrecovery.com)

# 12" Vertical Panels

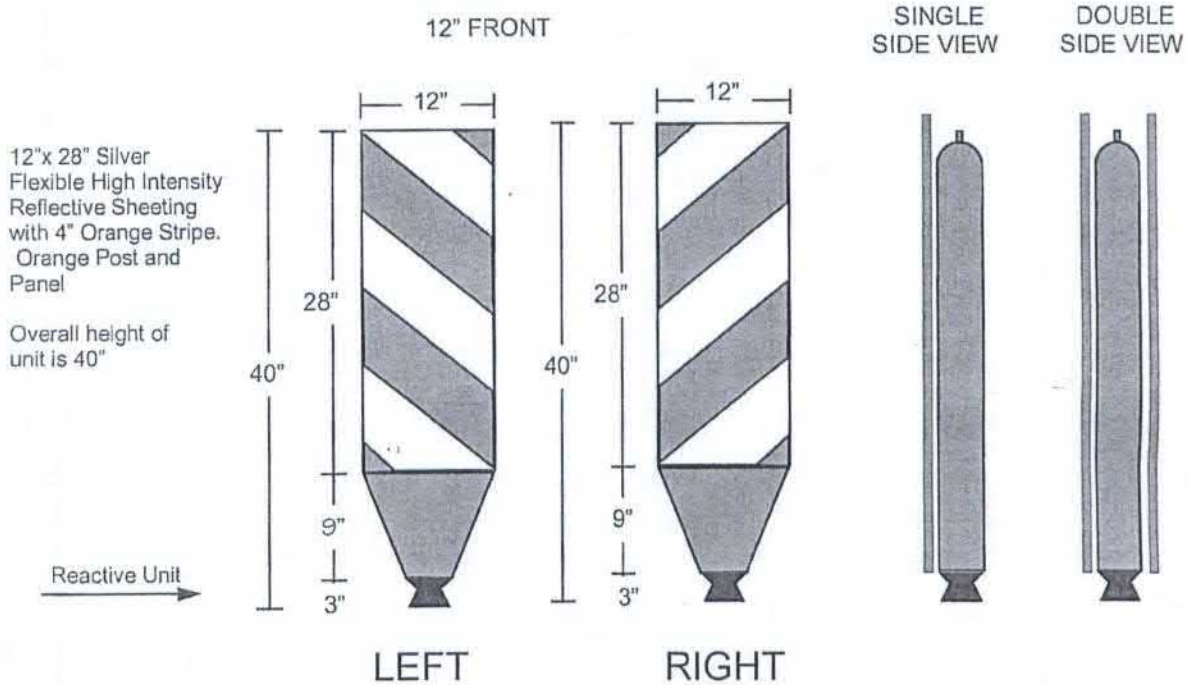

For Use With Tuff Curb XLP

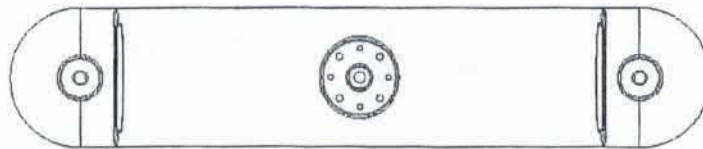

### SPECIFICATIONS

- Post and panel is constructed of flexible polyethylene plastic that is resistant to: ultraviolet light, ozone, and hydrocarbons.
- Single Paneled Unit has a reactive spring assembly tested at 145 lb. tension with stainless steel cable. Double Paneled unit has a 145 lb. spring.

### RECOMMENDED USES

- Ideal for use with confusing work zones, provides uninterrupted work zone channelization. Provides high target value and stays in place when impacted.

**IMPACTrecovery**  
**SYSTEMS**

*Performance for a Safer Tomorrow*

4955 Stout Dr. San Antonio, TX 78219  
210.736.4477, 800.736.5256, fax: 210.734.6448  
[www.impactrecovery.com](http://www.impactrecovery.com)



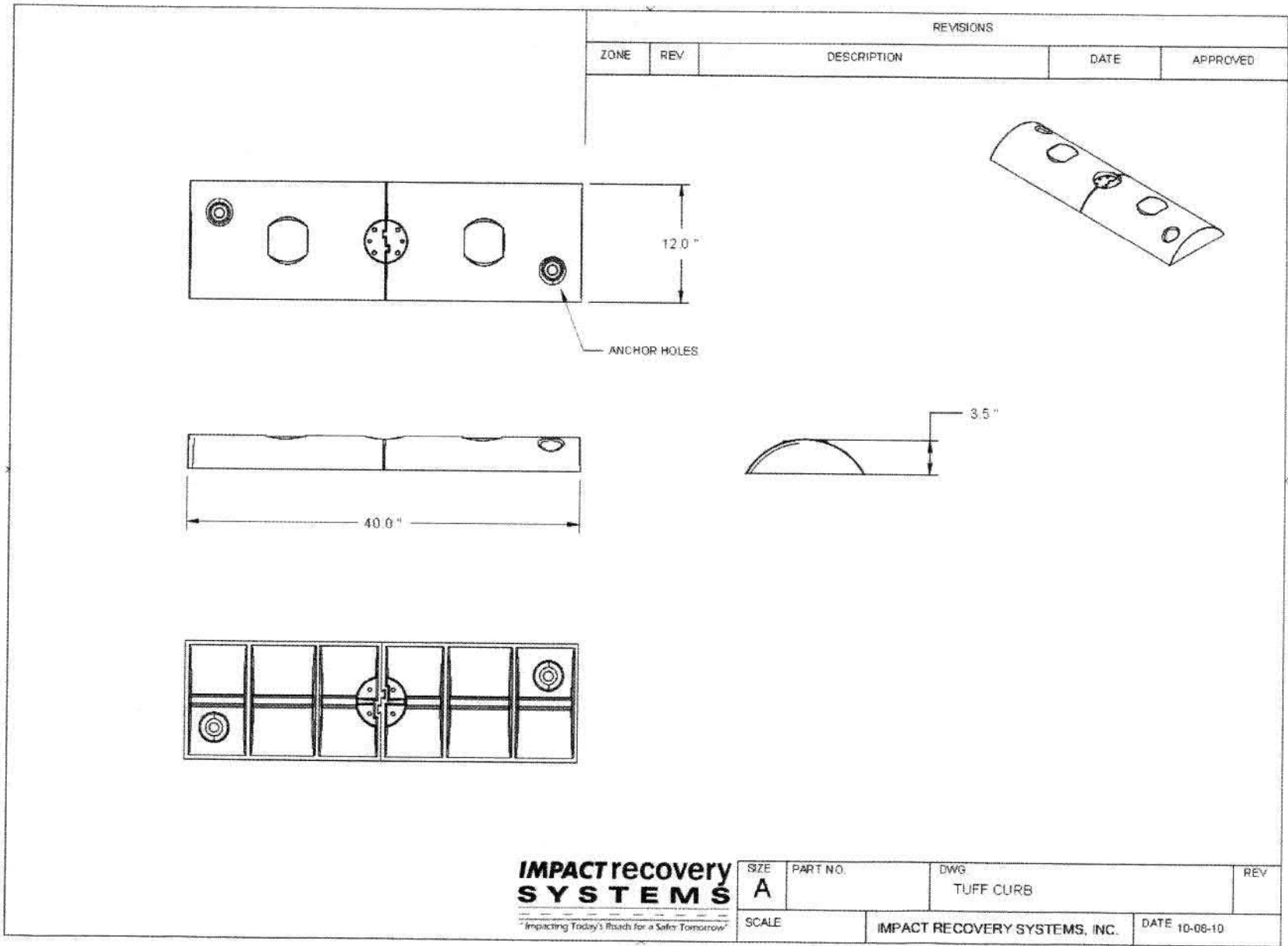

**IMPACT recovery SYSTEMS**  
 "Impacting Today's Risks for a Safer Tomorrow"

|                  |           |                               |               |
|------------------|-----------|-------------------------------|---------------|
| SIZE<br><b>A</b> | PART N.O. | DWG<br>TUFF CURB              | REV           |
| SCALE            |           | IMPACT RECOVERY SYSTEMS, INC. | DATE 10-08-10 |

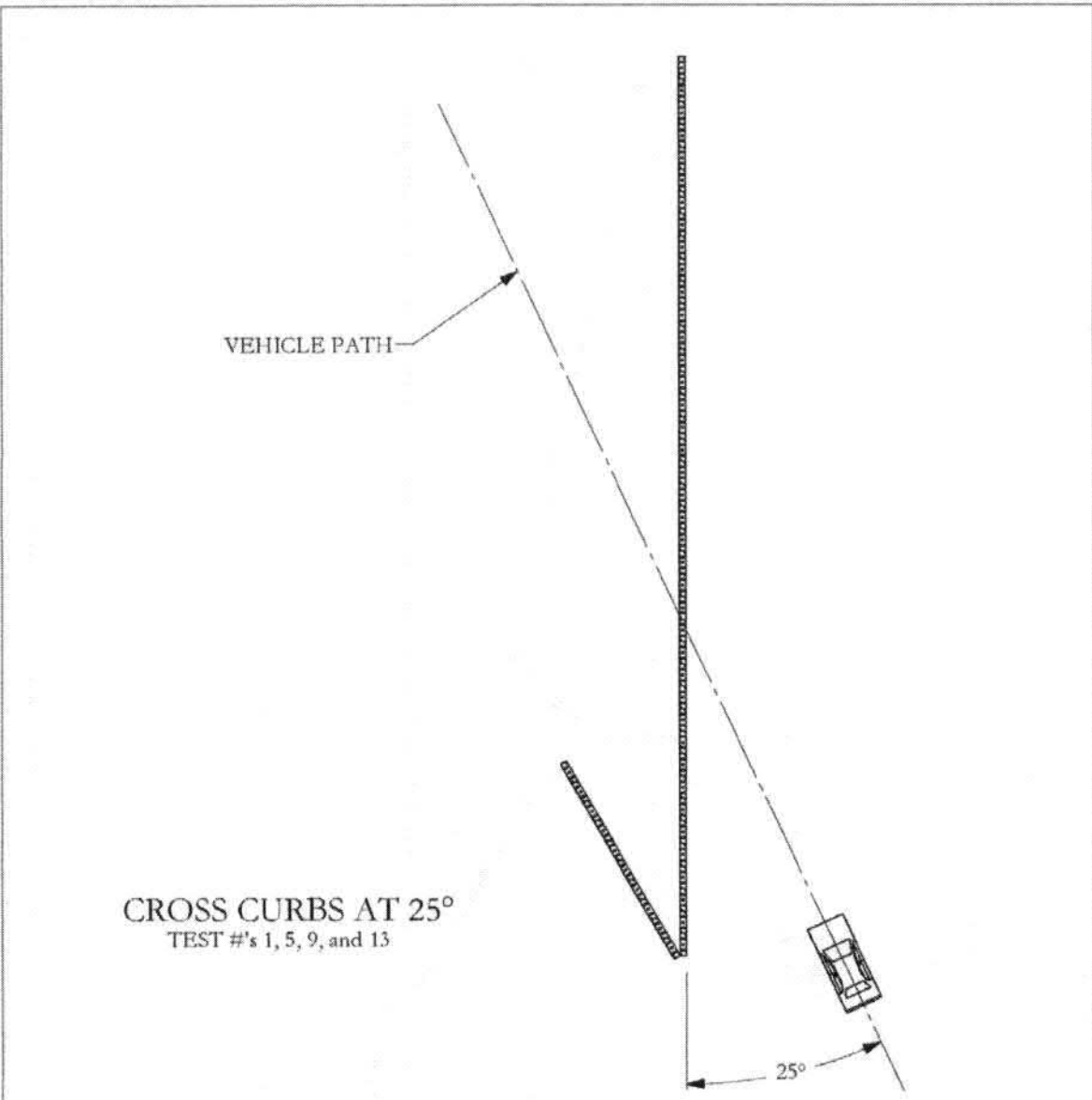

CROSS CURBS AT 25°  
TEST #'s 1, 5, 9, and 13

| The Texas A&M University System |      |    |     |   |          |                     |           |
|---------------------------------|------|----|-----|---|----------|---------------------|-----------|
| Revisions:                      |      |    |     | Texas Transportation Institute<br>College Station, Texas, 77843 |          |                     |           |
| No.                             | Date | By | Chk | Date  | Drawn By | Scale               | Sheet No. |
| 1.                              |      |    |     | 2010-12-15  | GES      | 1:250               | 1 of 4    |
| 2.                              |      |    |     | Project No.   |          | 25°                 |           |
| 3.                              |      |    |     | 400001-IRS  |          |                     |           |
| 4.                              |      |    |     | Impact Recovery Systems   |          |                     |           |
| 5.                              |      |    |     |   |          |                     |           |
| Approved:<br>Dusty Arrington:   |      |    |     | Signature:  |          | Date:<br>2010-12-15 |           |

T:\2010-2011\400001\IRS - Impact Recovery Systems\Drafting\Drawings\IRS Test Paths Drawing

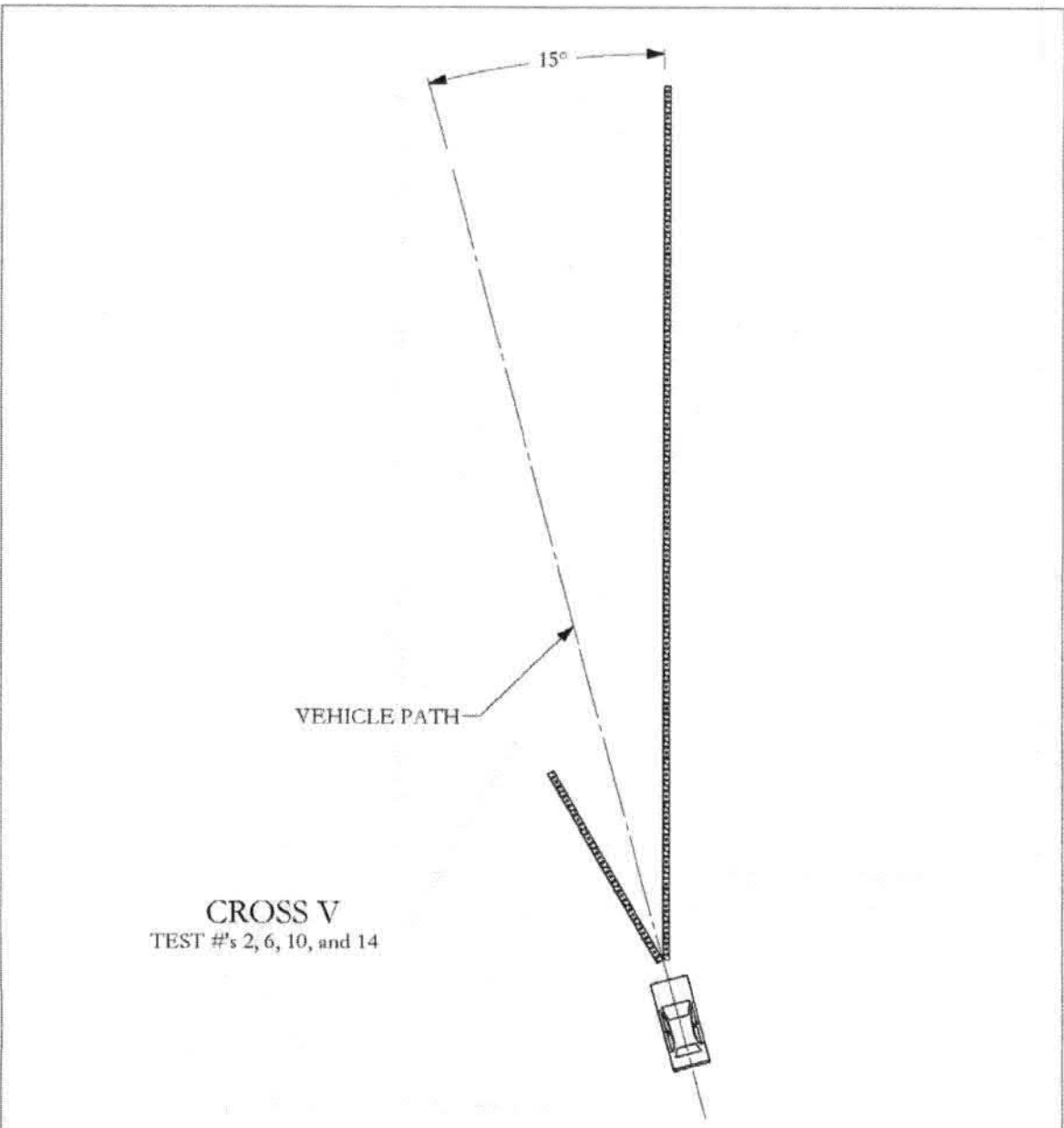

CROSS V  
TEST #'s 2, 6, 10, and 14

| The Texas A&M University System |      |    |     |   |          |       |           |
|---------------------------------|------|----|-----|---|----------|-------|-----------|
| Revisions:                      |      |    |     | Texas Transportation Institute<br>College Station, Texas, 77843 |          |       |           |
| No.                             | Date | By | Chk | Date  | Drawn By | Scale | Sheet No. |
| 1.                              |      |    |     | 2010-12-15  | GES      | 1:250 | 2 of 4    |
| 2.                              |      |    |     | Project No.   |          | V     |           |
| 3.                              |      |    |     | 400001-IRS  |          |       |           |
| 4.                              |      |    |     | Impact Recovery Systems   |          |       |           |
| 5.                              |      |    |     |   |          |       |           |

T:\2010-2011\400001-IRS - Impact Recovery Systems\Drafting\Drawings\IRS Test Paths Drawing

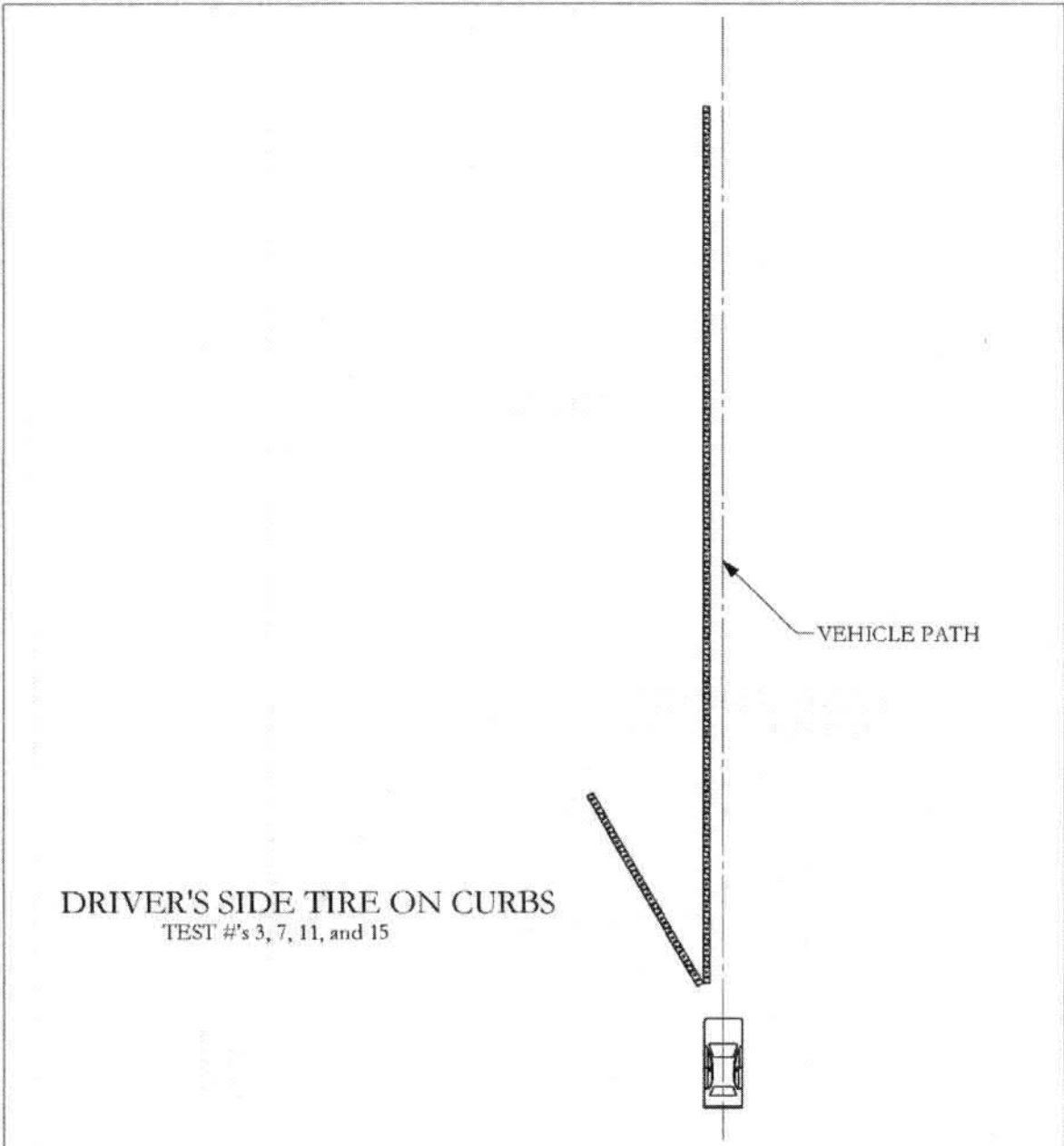

**DRIVER'S SIDE TIRE ON CURBS**  
 TEST #'s 3, 7, 11, and 15

VEHICLE PATH

T:\2010-2011\400001\IRS - Impact Recovery Systems\Drafting\Drawings\IRS Test Paths Drawing

| The Texas A&M University System |      |    |     |   |          |       |           |
|---------------------------------|------|----|-----|---|----------|-------|-----------|
| Revisions:                      |      |    |     | Texas Transportation Institute<br>College Station, Texas, 77843 |          |       |           |
| No.                             | Date | By | Chk | Date  | Drawn By | Scale | Sheet No. |
| 1.                              |      |    |     | 2010-12-15  | GES      | 1:250 | 3 of 4    |
| 2.                              |      |    |     | Project No.   |          | 0°    |           |
| 3.                              |      |    |     | 400001-IRS  |          |       |           |
| 4.                              |      |    |     | Impact Recovery Systems   |          |       |           |
| 5.                              |      |    |     |   |          |       |           |



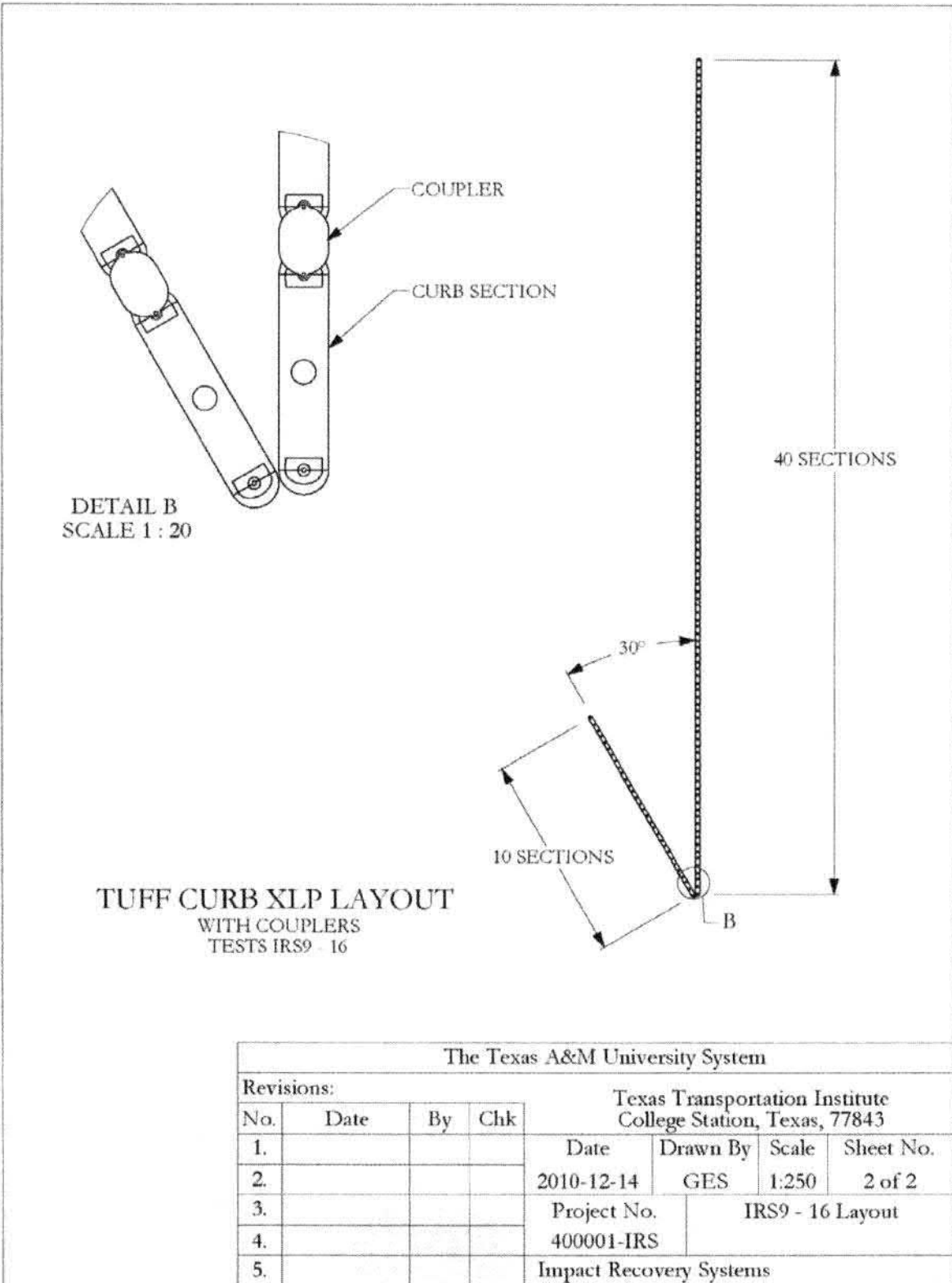

T:\2010-2011\400001\IRS - Impact Recovery Systems\Drawings\Drawings\IRS Layout Drawing

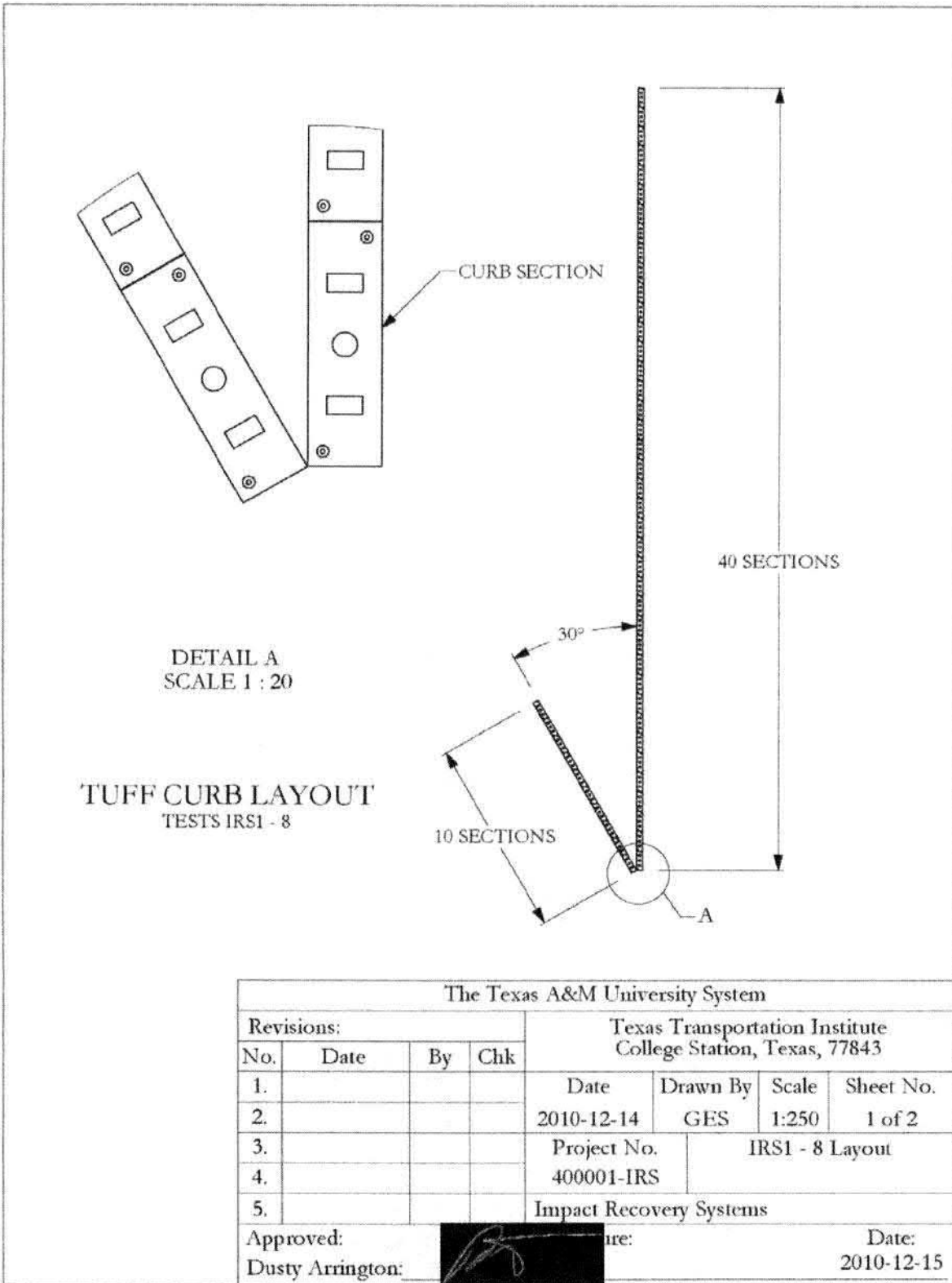

T:\2010-2011\400001\IRS - Impact Recovery Systems\Drafting\Drawings\IRS Layout Drawing

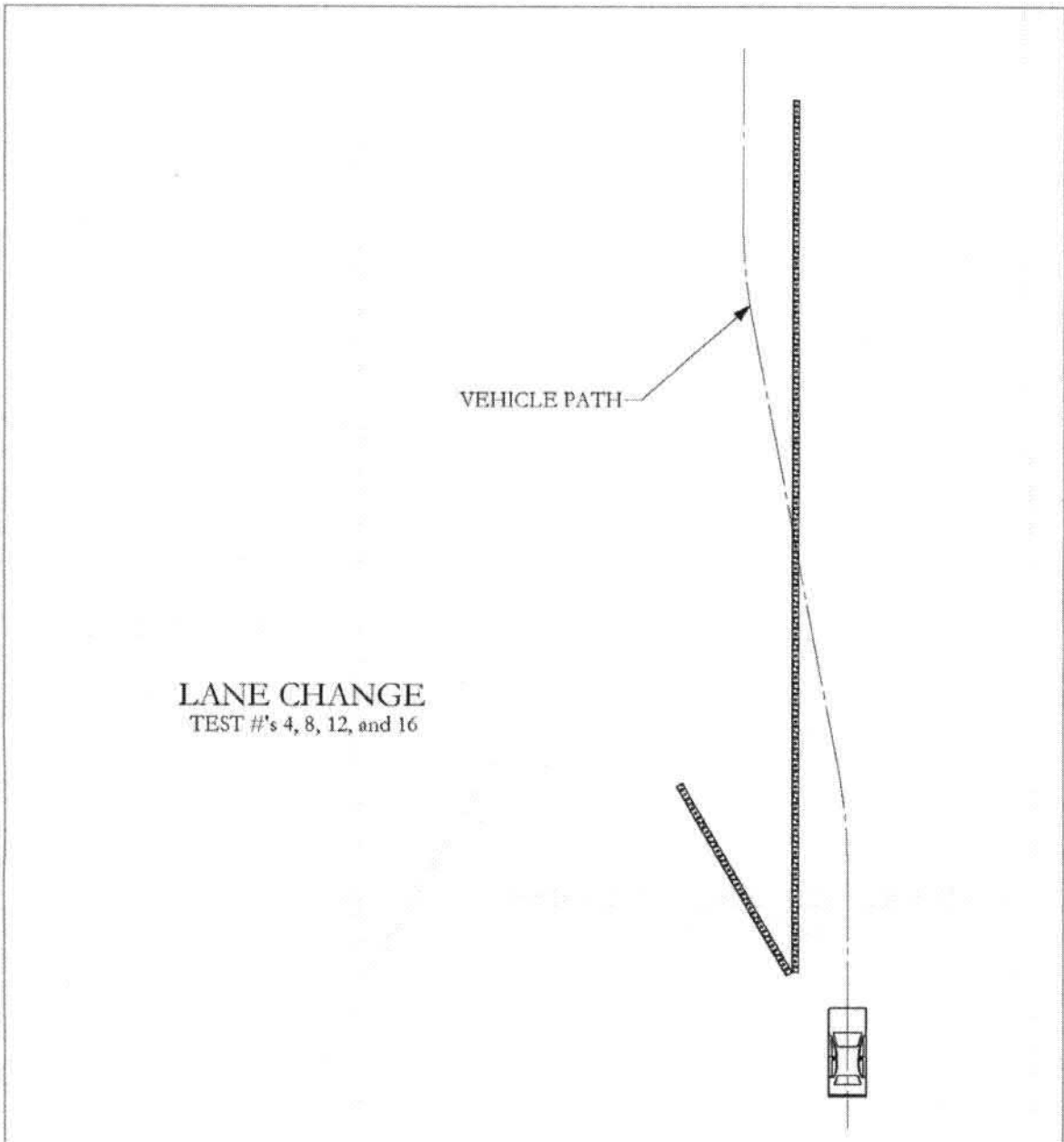

**LANE CHANGE**  
TEST #'s 4, 8, 12, and 16

VEHICLE PATH

|                                 |      |    |     |   |          |             |           |
|---------------------------------|------|----|-----|---|----------|-------------|-----------|
| The Texas A&M University System |      |    |     |   |          |             |           |
| Revisions:                      |      |    |     | Texas Transportation Institute<br>College Station, Texas, 77843 |          |             |           |
| No.                             | Date | By | Chk | Date  | Drawn By | Scale       | Sheet No. |
| 1.                              |      |    |     | 2010-12-15  | GES      | 1:250       | 4 of 4    |
| 2.                              |      |    |     | Project No.   |          | Lane Change |           |
| 3.                              |      |    |     | 400001-IRS  |          |             |           |
| 4.                              |      |    |     | Impact Recovery Systems   |          |             |           |
| 5.                              |      |    |     |   |          |             |           |

T:\2010-2011\400001\IRS - Impact Recovery Systems\Drafting\Drawings\IRS Test Paths Drawing

# Tuff Curb XLP

## 40" Section

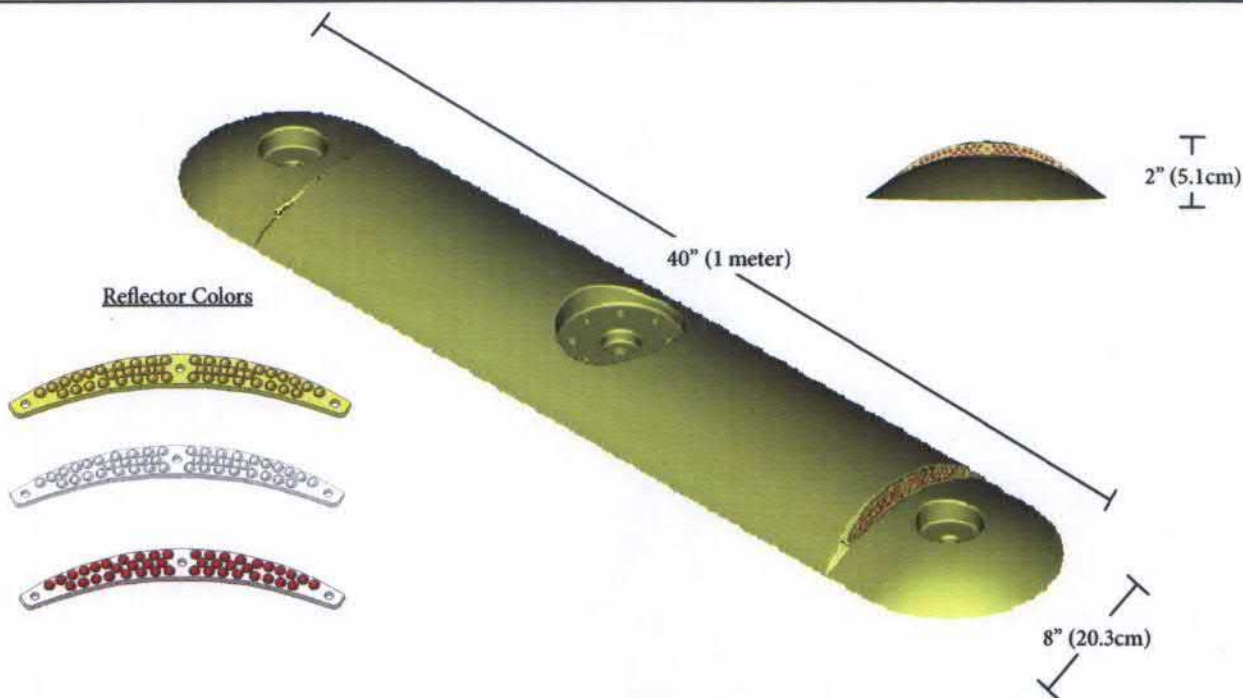

### OPTIONAL BETWEEN CURB COUPLER

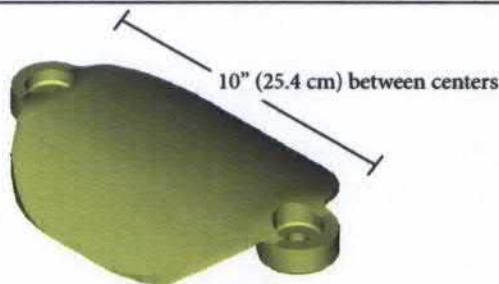

#### SPECIFICATIONS

- Tuff Curb XLP is molded from a single piece of durable HDPE and utilizes IRS's patented reboundable spring post system
- Withstands 20,000 pounds of static force from a single wheel
- Efficient installation with 2-3 mechanical anchors or epoxy
- Optional coupler between curbs for clean unified curb
- Curved reflectors exceed ASTM D4280 min. reflectance levels
- Successfully M.A.S.H. tested Jan 2011
- #WZ-XXX approval—pending
- 40" curb section weighs 6.5 lbs.

#### RECOMMENDED USES

- Ideal for use for demanding high speed applications as well as city streets, bridges, and parking decks
- Use only with IRS posts or signs attached
- See installation instructions for detailed usage recommendations

#### AVAILABLE COLORS

- White (white or white/red reflectors)
- Yellow (yellow reflectors)
- Other colors available on special order (minimum quantities required)

**IMPACT**recovery  
**S Y S T E M S**

"Performance for a Safer Tomorrow"

4955 Stout Dr. San Antonio, TX 78219  
210.736.4477, 800.736.5256, fax: 210.734.6448  
www.impactrecovery.com

January 2011



# **INSTALLATION INSTRUCTIONS FOR TUFF CURB® XLP**

**Multi-Surface Anchors  
Concrete Anchors  
#160/161 Epoxy Kit  
#163 Super Bundy®**

**NOTE: BITUMINOUS PRODUCTS CANNOT  
BE USED TO INSTALL TUFF CURB XLP**

**Revised  
January 2011**

**IMPACT RECOVERY SYSTEMS, INC.  
4955 STOUT DRIVE  
SAN ANTONIO, TEXAS 78219  
(210) 736-4477 TOLL-FREE (800) 736-5256  
FAX (210) 734-6448  
[www.impactrecovery.com](http://www.impactrecovery.com)  
[www.impactrecovery.eu](http://www.impactrecovery.eu)**

# MULTI-SURFACE ANCHORS INSTALLATION INSTRUCTIONS

**Anchor kit consists of: 3" Plastic Anchors, 4" Lag Screws, Metal Washer**

## **Materials Needed for Installation**

Hammer Drill with 16mm or 5/8" Bit  
Small Hammer  
1/4" Allen Wrench (fixed post only)  
3/4" socket and ratchet wrench or impact wrench  
Compressed Air with air gun or wand



## **INSTALLATION INSTRUCTIONS:**

1. Place Tuff Curb XLP on surface and align to desired position (per detailed traffic engineering plans). Using the curb as a template, mark the anchor holes to establish pattern for drill.
2. Drill two or three holes 4" deep using a 16mm or 5/8" bit. Clean holes out thoroughly using compressed air.



3. Using small hammer gently tap the anchors into the holes.

4. Place curb over the anchors. Put washer onto lag screw. Start lag screw through curb hole into anchor. Use  $\frac{3}{4}$ " wrench to tighten lag screw snug into base. If couplers are to be used, couplers must be set in place prior to inserting bolts.



5. For Quick Release post assemblies, lift pull pin ring, place knuckle over shoulder bolts, turn clockwise into place and release pull pin ring until properly seated. For fixed post assemblies, place the sign or post into curb receptacle, check for proper alignment, hand tighten all four socket cap screws. Use  $\frac{1}{4}$ " Allen wrench to snug screws.

## GENERAL NOTES

1. Curb should always be used with delineator posts or hazard markers. Use only IRS spring systems and posts. Curb has been designed for Yellow 110 or Black 145 springs.
2. Three anchors are required when vehicle speeds are expected to be 45mph or greater. Two anchors located on the outer mounting holes may be used otherwise; however three anchors will always provide superior mounting.
3. Epoxy is recommended for all speed levels.
4. Super Bundy® installation is only recommended for low speed applications (30mph or less).
5. Spacing between curb sections without couplers is recommended at 1" to 4".
6. Spacing between curb sections with couplers is 2".
7. It is recommended to use a minimum of four (4) curb sections to create a 90 degree turn. Use more as needed.
8. Couplers should be at an angle no greater than 30 degrees to any curb section. It is possible to create a 90 degree section with three (3) sections using couplers each at 15 degrees, however this is not recommended for street traffic.
9. Metal washers are not needed when installing couplers with the concrete installation kit.

# CONCRETE ANCHORS INSTALLATION INSTRUCTIONS

**Anchor Kit consists of: 4" Wedge Bolt, Metal Washer**

## Materials Needed for Installation

Hammer Drill with 1/2" Bit  
1/4" Allen Wrench (fixed post only)  
3/4" socket and ratchet wrench or impact wrench  
Compressed Air with air gun or wand



## INSTALLATION INSTRUCTIONS:

1. Place Tuff Curb XLP on surface and align to desired position (per detailed traffic engineering plans). Using the curb as a template, mark the anchor holes to establish pattern for drill.
2. Drill two or three holes 4" deep using ANSI 1/2" bit. Clean holes out thoroughly using compressed air.
3. Place curb over the anchors. Put washer onto lag bolt. Start lag bolt through curb hole into anchor. Use 3/4" wrench to tighten lag screw snug into base. If Turtle couplers are to be used, couplers must be set in place prior to inserting bolts.
4. For Quick Release post assemblies, lift pull pin ring, place knuckle over shoulder bolts, turn clockwise into place and release pull pin ring until properly seated. For fixed post assemblies, place the sign or post into curb receptacle, check for proper alignment, hand tighten all four socket cap screws. Use 1/4" Allen wrench to snug screws.



# EPOXY ADHESIVE INSTALLATION INSTRUCTIONS

***FOR BEST RESULTS CLOSELY FOLLOW THE EPOXY MANUFACTURER'S  
INSTALLATION INSTRUCTIONS.***

1. Place four (4) small pieces of tape on the bottom of the curb to cover t-nuts. Tape prevents epoxy from entering screw threads upon installation.
2. Pavement surface should be clean and dry. Clean as necessary.
3. For increased adhesion, flame-treat the underside of the curb prior to installation. Quickly passing a cool flame over the plastic surface will increase surface preparation.
4. Mix epoxy as directed and closely follow instructions on epoxy container. Time,.
5. Approximately 40 to 50 oz. of epoxy are required per curb section (without coupler). A two gallon epoxy kit should install 5-6 curb sections.
6. Align curb per detailed traffic engineering plans and roughly mark outline of curb. Pour epoxy on ground in an area slightly larger than curb outline. Push curb into epoxy and slowly wiggle back and forth in epoxy, filling underside channels with epoxy. Allowing epoxy to fill anchor holes will increase adhesion through mechanical bonding. Ensure the middle section receives the greatest amount of epoxy, followed by the extreme ends of the curb, closest to the epoxy holes.

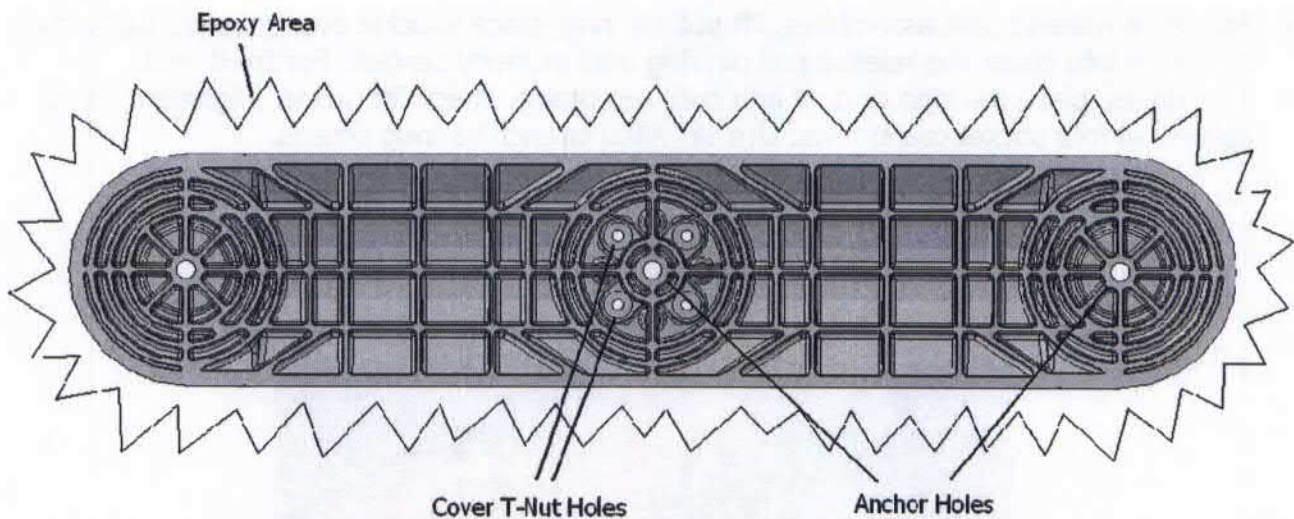

# SUPER BUNDY®

## INSTALLATION INSTRUCTIONS

### Materials Needed for Installation

Chalk Line  
Propane Torch  
Compressed Air with air gun or wand

### INSTALLATION INSTRUCTIONS:

1. Pavement surface should be clean and dry. Clean as necessary.
2. Snap a chalk line in the desired position of the curb (per detailed traffic engineering plans). Place curb to the side of desired position to use as a guide for placement of Super Bundy® pads.
3. Heat the surface prior to placement of pads.



4. Place three pads on the surface, one at each anchor location covering the circular pattern on the underside of the curb, and heat the pad to its melting point.



7. If couplers are used, pour epoxy in the area between curbs as well as on the underside of the coupler at the curb cup area. Place the coupler on top of the curb such that epoxy mates with curb. Add epoxy to anchor holes to complete the adhesion.

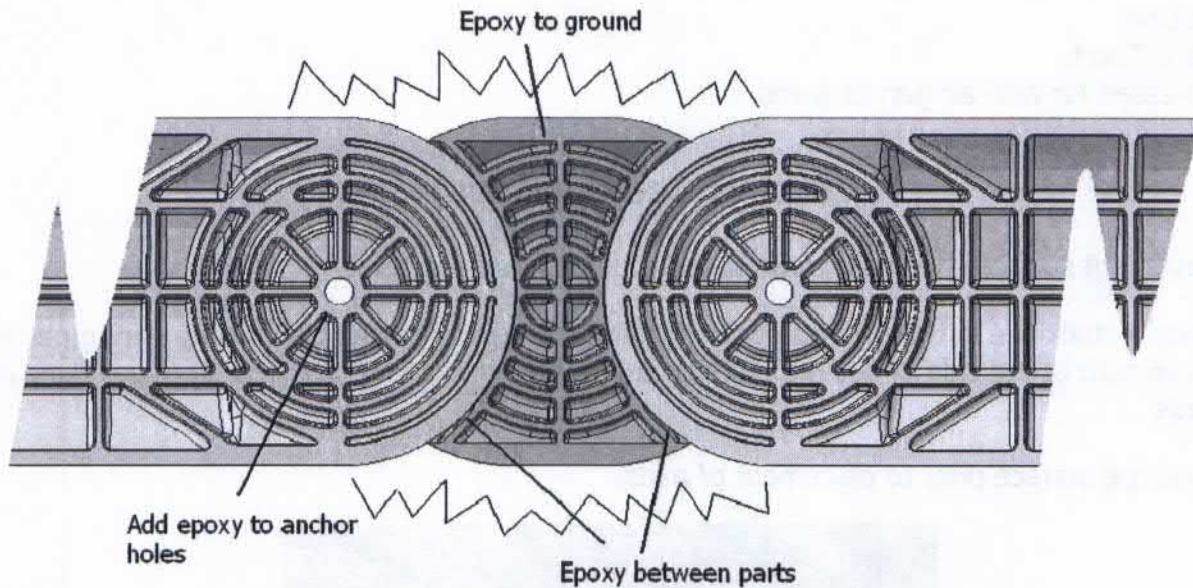

8. Allow epoxy to dry 24 hours for optimum performance. Most epoxies are temperature sensitive. Take care to follow manufacturer's recommendations.
9. For fixed post assemblies, place the sign or post into curb receptacle, check for proper alignment, hand tighten all four socket cap screws. Use  $\frac{1}{4}$ " Allen wrench to snug screws. For Quick Release post assemblies, lift pull pin ring, place knuckle over shoulder bolts, turn clockwise into place and release pull pin ring until properly seated.

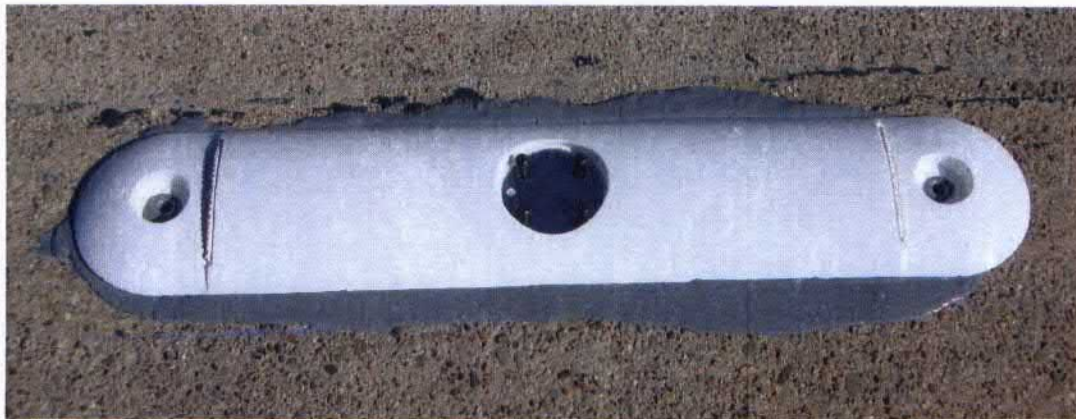



5. Place a second set of pads on top of the first set and heat each to its melting point as in the previous step. Super Bundy® always requires two pads on top of each other.



6. Pushes curbs gently into Super Bundy® pads and slowly wiggle back and forth, taking care not to push all the way through pads. Allow one hour to cure.



---

# IMPACT recovery SYSTEMS

---

" Impacting Today's Roads for a Safer Tomorrow"

4955 Stout Dr.  
San Antonio, TX 78219  
Phone (210) 736-4477 (800) 736-5256  
Fax (210) 734-6448  
www.impactrecovery.com

## TERMS AND CONDITIONS OF SALE

July 2008

1. **Prevailing Terms and Conditions:** All products manufactured by Impact Recovery Systems (IRS), described in this invoice are sold pursuant to the final Terms and Conditions of Sale hereinafter set forth. Any and all conflicting, contrary, or inconsistent terms contained in any purchase order or confirmatory memoranda issued by Buyer, its agents or representatives, are hereby expressly rejected as being contrary to the terms hereinafter set forth and shall not form a part of this sales transactions.
  2. **Product Usage/Approvals:**
    - a. Buyer acknowledges that it shall only use the products obtained from IRS for the purposes for which the products are sold as represented in the sales literature published by IRS. Buyer further acknowledges that it, as well as, its agents, representatives, subcontractors and purchasers, shall follow explicitly the installation instructions furnished by IRS, and any material failure to abide by such installation instructions or the usage of such product in or for applications not recommended by IRS, shall constitute a waiver of the express warranties contained herein.

IRS does not represent or warrant that its product is suitable for use or has been approved for use by the transportation authorities within the locality or state within which Buyer intends to sell or utilize the product. Buyer warrants that it shall independently secure the necessary approvals of said transportation or other proper authorities regarding the intended specific use or application of the product sold by IRS.
  3. **Warranty:** IRS represents and warrants that its products will (i) conform to its specifications; (ii) be fit and sufficient for the purpose(s) for which they are sold; (iii) be new and free of material damage, (iv) be produced, shipped and performed in compliance with the requirements of all applicable laws and regulations, and (v) not infringe the intellectual property rights of any third-party.
  4. **DISCLAIMER OF WARRANTIES:** EXCEPT FOR THE EXPRESS WARRANTIES CONTAINED IN THE AUTHORIZED BROCHURES AND PUBLICATIONS OF IMPACT RECOVERY SYSTEMS (IRS), TO THE MAXIMUM EXTENT PERMITTED BY APPLICABLE LAW, IRS DISCLAIMS AND EXCLUDES ALL REPRESENTATIONS AND WARRANTIES, WHETHER EXPRESS, IMPLIED OR STATUTORY, REGARDING IN ANY MANNER ITS PRODUCTS OR PRODUCT CONDITIONS, INCLUDING, WITHOUT LIMITATION, THAT OF MERCHANTABILITY, SUITABILITY, ORIGINALITY, FITNESS FOR A PARTICULAR USE OR PURPOSE, OR A RESULT TO BE DERIVED FROM THE USE OF ITS PRODUCTS. BUYER ACKNOWLEDGES THAT IT IS A SOPHISTICATED USER OF TRAFFIC DELINEATION AND WORK ZONE PRODUCTS, AND AGREES THAT THIS PROVISION IS AN INTEGRAL PART OF IRS' PRICING AND AN IMPORTANT FACTOR IN ITS WILLINGNESS TO PROVIDE/SELL SUCH PRODUCTS TO BUYER.
  5. **LIMITATION OF LIABILITY:** IRS AND IT'S DISTRIBUTOR'S AGGREGATE CUMULATIVE LIABILITY AND OBLIGATION SHALL BE TO REPLACE SUCH QUANTITY OF PRODUCT SOLD TO BUYER WHICH IS PROVEN TO BE DEFECTIVE OR NON-CONFORMING, IN A MANNER SUITABLE TO IRS TO ASCERTAIN THE DEFECT OR NON-CONFORMITY COMPLAINED OF IF REPORTED TO IRS IN WRITING WITHIN THIRTY (30) DAYS OF THE DISCOVERY OF THE DEFECT OR NON-CONFORMITY. NEITHER IRS OR ITS DISTRIBUTOR SHALL BE LIABLE EITHER IN TORT OR IN CONTRACT FOR ANY LOSS OR DAMAGE, DIRECT, INCIDENTAL, OR CONSEQUENTIAL, ARISING OUT OF THE USE, MISUSE, OR INABILITY TO USE THE PRODUCT SOLD BY IRS.
  6. **Indemnification:** To the fullest extent permitted by law, Buyer shall indemnify and hold harmless IRS, its affiliates and successors, and their respective officers, directors, employees, subcontractors and assigns, against
-



**City Post Model SM Channelizer Post**  
**Material Specifications**

1) Design

The City Post Model SM Surface Mount is a high-performance channelizer post system comprised of a tubular marker, a top cap and an integrated mounting base that work together for superior impact resistance and rebound.

All posts shall be capable of sustaining a minimum of one hundred (100) bumper and direct wheel-over impacts at 70 MPH (112 km/h) without damage to the posts.

2) Construction

The City Post SM Surface Mount shall consist of system comprised of a tubular marker, a top cap and an integrated mounting base assembly.

- a) The tubular marker portion shall consist of round post a minimum of 3.15” (80mm) in diameter, with 0.125” (3.2mm) thick walls (minimum). All posts shall be constructed of UV-stabilized thermo-plastic polyurethane (TPU) for superior toughness and rebound, conforming to the following material specifications:

| <b>Property</b>                     | <b>ASTM Test</b> | <b>Results</b> |
|-------------------------------------|------------------|----------------|
| Specific Gravity (min.)             | D 792            | 1.10           |
| Hardness (min.)                     | D 2240           | 90 A           |
| Tear Strength (min lb/in.)          | D 624, Die C     | 800            |
| Tensile Strength @ yield, (min PSI) | D 412            | 4,000          |
| Tensile Elongation @ break (min. %) | D 412            | 450            |
| Cold Temp. Impact Test (-7° F)      | FL/DOT           | Pass           |
| Gloss (min. units)                  | N/A              | 12.1           |

b) Mounting base assembly

The tubular marker portion shall be permanently bonded to the mounting base assembly. The post assembly shall be affixed to the roadway with mechanical fasteners, recommended Hilti HCA fasteners.

All mounting base assemblies shall be constructed of a UV-stable high-impact thermo-plastic alloy conforming to the following material specifications:

| <b>Property</b>          | <b>ASTM Test</b> | <b>Results</b> |
|--------------------------|------------------|----------------|
| Specific Gravity (min.)  | D 792            | 1.21           |
| Gardner Impact (min.)    | N/A              | 160            |
| Flexural Strength (min.) | D 790            | 20,000         |
| Shore Hardness           | D2240            | 55 D           |



- c) Top Cap  
The tubular marker portion shall also be permanently bonded to a polyurethane top cap. The Top Cap shall be provided with name of the manufacturer and a plurality of holes to allow the escapement of air when impacted, and also prevent the collection of rubbish or debris into the tubular marker portion of the post.
- 3) Standard and Florescent Colors  
City Post Surface SM Mounts shall be constructed of UV-stabilized polymers and colors. The color shall be solid throughout and stabilized to resist UV degradation. In construction work zone areas where orange devices are used, all posts shall be Florescent Orange to improve visibility in low light conditions.
- 4) Reflective Sheeting  
All City Post SM Surface Mounts shall have a minimum of two (2) 3-inch wide wraps of retro-reflective sheeting factory applied. The recommended reflective sheeting shall be an ASTM Type V abrasion resistant micro-prismatic sheeting the same color as the CP Surface Mount, applied two (2) inches down from the top with a two (2) inch gap between the two wraps.
- 5) Lengths  
City Post SM Surface Mounts shall be supplied in lengths from 18 to 48 inches, as specified in the construction plans or procurement details.
- 6) Installation  
The City Post SM Surface Mount assembly shall be installed to the roadway with mechanical fasteners, recommended Hilti HCA fasteners; see installation procedure.
- 7) NCHRP 350 Compliance  
The channelizer posts shall be fully crash-tested by an A2LA-certified testing facility and meet requirements for **Category 1** devices as specified in **NCHRP Report # 350**. Test reports and certifications of compliance with these standards must be supplied by the manufacturer upon request.
- 8) MASH-16 Compliance  
The channelizer posts shall be low-mass tubular markers with no attachments to the device, shall be fully crash-tested by an A2LA-certified testing facility and comply with the requirements of **MASH-16**. Test reports and certifications of compliance with these standards must be supplied by the manufacturer upon request.
- 9) Quality  
The channelizer posts shall be manufactured by an ISO 9001 certified firm in good standing; evidence of ISO compliance shall be presented as a pre-condition for acceptance for use.



10) Warranty

City Posts 36" and shorter in length shall be covered by warranty for a period of one (1) year from the date of purchase covering breakage of the posts; a copy of the manufacturers' warranty document shall be provided by the supplier upon request.

11) Manufacturer

The device above is manufactured by Pexco LLC - Davidson Traffic Control Products, Tacoma, WA, USA, phone (253) 284-8000, email [hwysales@pexco.com](mailto:hwysales@pexco.com)